

5

*Single, Double  
or Self-centering!*

**FMS**

**Morse e Cubi / Vises & Vise Towers**

INDICE - INDEX

pages		pages		pages		pages		pages	
Art.	5.	Art.	5.	Art.	5.	Art.	5.	Art.	5.
62	50	805M	55	810X	27	860C	44 - 45		
62K	67 - 69	805N	54 - 55	810XA	27	860D	14		
81P	50	805O	54 - 55	810Y	27	860E	14		
84U	31	805P	55	810YA	27	860F	14		
90	35	805Q	55	810Z	27	863	16		
99A	67 - 69	805R	55	812	31	863C	46		
99B	67 - 69	805T	55	812A	31	863D	16		
99H	67 - 69	805U	31	812B	31	863E	16		
99S	67 - 69	805UA	31	812C	31	863F	16		
220 G01	58	805V	35	813	31	864	18		
220 G02	58	805VA	35	813A	31	865	20		
220 G11	58	806	22	813C	31	865D	20		
266B	62 - 63 - 64	806A	22	814	56	865E	20		
247T	35	806B	23	815	31	865F	20		
375	61	806C	23	815A	31	866	24		
512	57	806D	23	815C	31	866D	24		
296	6	806E	23	818	52	866E	24		
547G	58	806F	22	821	53	866F	24		
547K	58	806G	23	822	53	867	28		
566	62	806H	23	823	59	867D	28		
571	62	806M	23	823B	59	867E	28		
800	38	806K	23	825	59	867F	28		
800A	38	806SLD	23	825A	61	868	32		
800B	38	806SLE	23	825B	59	868D	32		
800C	42-43	807	22	825C	59	868E	32		
800D	38	807A	22	827A	60	868F	32		
800E	61	808	22	828A	60	870	36		
800G	42-43	808A	22	829A	52	870A	54		
800I	61	808B	22	830	52	870C	46		
800Z	38 - 39	810	56	831	59	870D	36		
801	50	810A	56	832	59	870E	36		
801G	61	810B	56	833	59	870F	36		
801H	61	810D	56	834	59	882A	38		
801I	61	810DT	57	835	60	890	62 - 65		
801S	61	810E	57	836	60	890K/1	62		
802	72	810J	56 - 57	837	60	890K/2	63		
804	49	810K	57	838	60	890K/3	63		
805	54	810L	57	850B	61	890K/4	64		
805A	54	810M	57	850C	61	891	62		
805B	54	810O	56 - 57	850E	61	892	62		
805C	54	810P	57	850H	61	900	40		
805D	55	810Q	31	850P	72	900Y	40		
805DT	55	810QA	31	850T	61	983	3		
805E	55	810R	57	852	60	DPG250	66		
805F	54 - 55	810T	57	853	60	DIVIGER 205	68		
805G	55	810U	31	855	12				
805H	55	810UA	31	855C	44 - 45 - 48				
805I	55	810UZ	31	855D	12				
805J	55	810V	57	855E	12				
805K	55	810W	27	855F	12				
805L	55	810WA	27	860	14				

VALIGETTA DI CAMPIONATURA FMS (Art.860)  
FMS SAMPLE KIT CASE (Art.860)

NEW



Art. 983  
Valigetta di campionatura morsa Art.860 T.1x300  
Sample kit case Art.860 T.1x300 vise

Cod. 0.98.30000

All'Interno - Inside:

Art.810L	Art. 806B	Art.297 16/18
Art. 807	Art. 806C	Art.850H
Art. 810X	Art.806D	Art.370 T1 Std
Art. 814	Art.806E	Art.375 CH12
Art. 810J	Art.806F	-
Art. 814	Art.298	-



SIMBOLOGIA DATI TECNICI  
TECHNICAL DATA ICONS

<b>GANASCE JAWS</b>					
	Piane Straights	A gradino With step	Oscillanti Floating	Oscillanti con inserti regolabili Floating with inserts adjustable	Prismatiche Prismatic
<b>PIASTRE GANASCE JAW PLATES</b>					
	Discendente Pull down	Piana Straight	Cambio rapido manuale Quick manual change	GRIP GRIP	Inserti GRIP Inserti GRIP
<b>POSSIBILITÀ POSSIBILITY</b>					
	Serraggio singolo Single clamping	Serraggio doppio Double clamping	Predisposizione Zero Point Zero Point Ready	Cubi-morsa Vise tower	Divisore Automatico Automatic dividing head
<b>PAGINE PAGES</b>					
	Lavorazioni a 5 assi 5 axis machining	Accessori & Ricambi Accessories & Spare Parts	Istruzioni corretto utilizzo Instruction for a proper use	Diagrammi forze di serraggio Clamping force diagrams	Sistema Idraulico Hydraulic System

## Morse e cubi morsa / Vises & vise-towers

# FMS SERIES

Un sistema modulare flessibile con centinaia di ganasce disponibili

A Flexible modular system with hundreds of jaws available

### ESTREMA VERSATILITÀ / EXTREME VERSATILITY

- 3 posizioni per la ganascia fissa; • Serraggio dall'esterno all'interno e viceversa;
- Posizionamento verticale-orizzontale-laterale; • Collegamento: fianco a fianco, dorso a dorso, fianco a dorso; • Possibilità illimitata per ganasce speciali; • Sostituzione semplice e precisa delle ganasce;
- Elemento di prolunga per pezzi fuori misura; • Sistema di serraggio meccanico, idraulico, pneumatico elettrico o con moltiplicatore di potenza, tramite comando manuale, a pedale o mediante pulsante elettrico (vedi pag. 12); • Costruzione solida e compatta e massima apertura rispetto alla sua lunghezza;
- Flessioni praticamente ridotte di due volte rispetto alle precedenti morse modulari standard; • Accurata ripetibilità di posizionamento del pezzo da lavorare; • Precisioni geometriche con tolleranze entro 0,02 mm; • Protezione integrale dalla penetrazione di corpi estranei tramite piastre scorrevoli; • Possibilità di trasformazione di ogni morsa singola in morsa autocentrante o in morsa doppia tramite la semplice sostituzione delle ganasce sul corpo base universale. (ESEMPI APPLICATIVI A PAGINA 5.76).

- 3 positions for the fixed jaw; • Outside to inside clamping and viceversa; • Vertically, horizontally and sideways vise positioning; • Side to side, back to back and back to side vise positioning; • Unlimited special jaws; • Simple and precise exchange of jaws; • Extension element for extra-long pieces; • Mechanic, hydraulic or pneumatic or electrical clamping system or with pressure multiplier, through manual, pedal or push button board control (see page 12); • Space saving design, solid construction and maximum blocking ratio to total length; • Deflection reduced two times with respect to the STANDARD modular vises; • Very accurate repeatability of workpiece position; • Geometrical accuracy with tolerances within 0,02 mm; • Integral protection from chips and dirty through sliding protection; • Possibility to transform each single vise in a self-centering vise with possibility to block from outside to inside and vice versa and in a double vise through the simple substitution of the jaws on the universal vise body base. (APPLICATION EXAMPLES ON PAGE 5.76)



Precisione / Accuracy  
 $\pm 0,02\text{mm}$



Durezza / Hardened  
**HRC 58 $\pm$ 2**

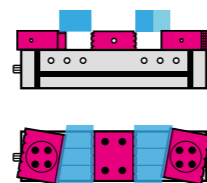

**Ganasce Mobili Oscillanti**  
per serraggio di pezzi irregolari  
*Floating Movable Jaws*  
for irregular workpieces

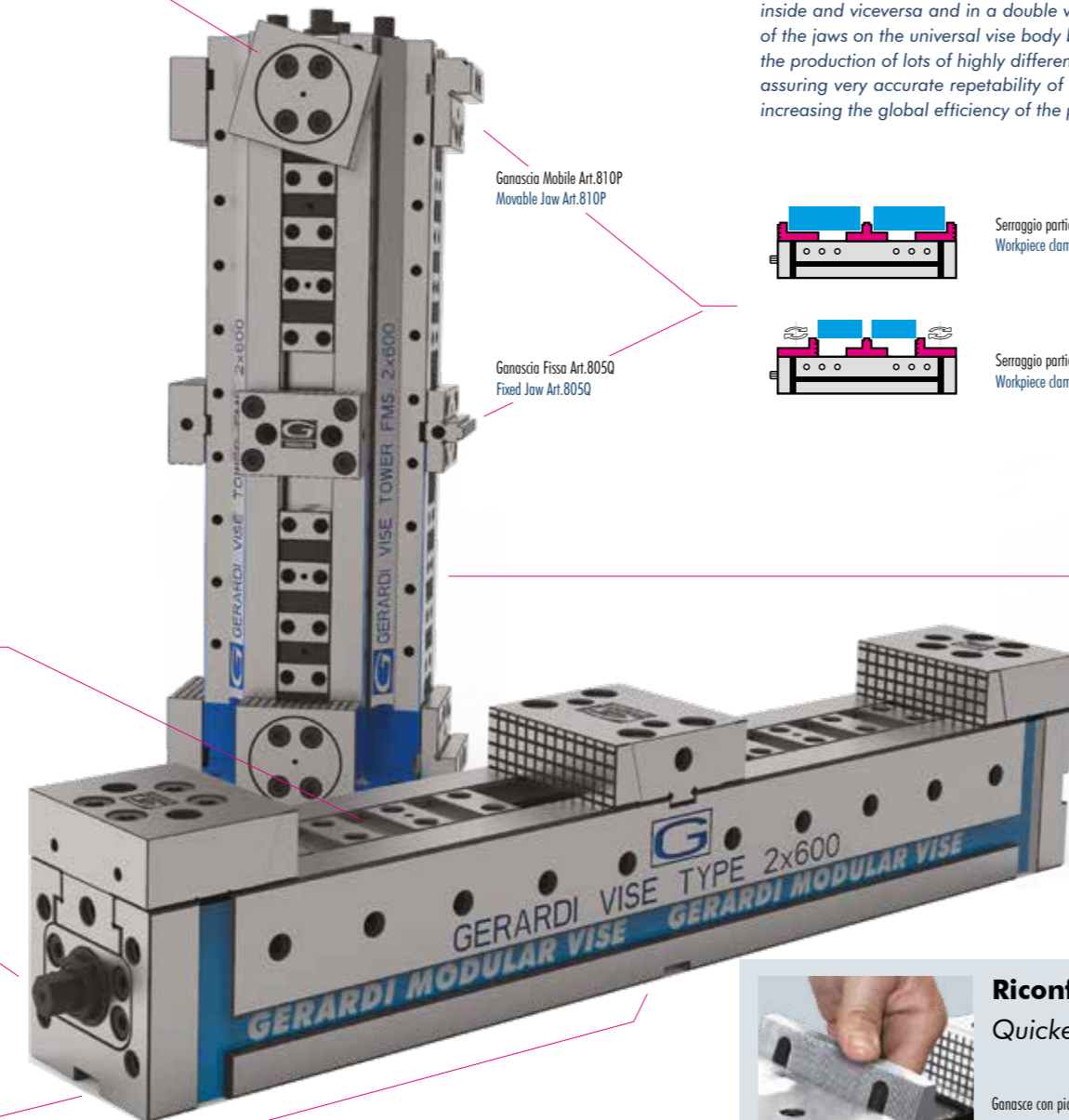

Ganascia Mobile Art.810P  
Movable Jaw Art.810P

Ganascia Fissa Art.805Q  
Fixed Jaw Art.805Q

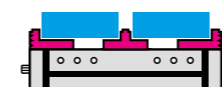

Serraggio particolare su gradino grande  
Workpiece clamping on the large step

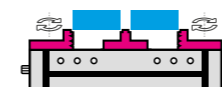

Serraggio particolare su gradino piccolo  
Workpiece clamping on the small step

Nata espressamente per i centri di lavoro, la gamma FMS permette ottimizzazioni di serraggio con riferimenti precisi in spazi contenuti, usure inesistenti e rigidità impensabile (spessore della base raddoppiato), possibilità di bloccare più pezzi contemporaneamente con l'ausilio di sistemi meccanici, pneumatici, elettrici o idraulici. Tutte sono disponibili/predisposte sia per piazzamenti verticali che orizzontali. Serraggi di qualsiasi lunghezza. La caratteristica (Brevettata) che meglio contraddistingue questa serie di morse consiste nella possibilità di trasformare ogni morsa singola (cioè adibita al serraggio di un singolo pezzo) in una morsa autocentrante con bloccaggio concentrico dall'esterno all'interno e viceversa e in morsa doppia tramite la semplice sostituzione delle ganasce sul corpo base universale. Tutto ciò ne suggerisce l'impiego in situazioni produttive caratterizzate da lotti di pezzi estremamente diversi fra loro riducendo tempi di set-up e garantendo un'accurata ripetibilità di posizionamento e quindi di precisione migliorando l'efficienza globale del sistema produttivo.

Born to be dedicated to machining centres, FMS series of vises allow workholdings with perfect alignment in a space saving design, extremely high wear resistance, with deflection reduced 2 times in respect to the STD modular vises (base thickness doubled), possibility to clamp more pieces simultaneously with mechanic, hydraulic pneumatic or electric devices. You can use them both for vertical and horizontal clamping without any price charge. Grip any work length. The feature (Patented) which identifies this line of vises consists in the possibility to transform each single vise (1 piece clamping) in a self-centering vise with possibility to block from outside to inside and viceversa and in a double vise through the simple substitution of the jaws on the universal vise body base. All that suggests their use in the production of lots of highly different pieces reducing set-up times and assuring very accurate repeatability of workpiece position and precision, increasing the global efficiency of the production process.

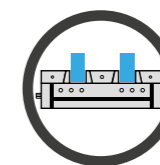

Singole, Doppie o Autocentranti!  
Single, Double or Self-centering!



### 3 Morse in Una 3 Vises in One

Possibilità di trasformare ogni morsa singola in una morsa autocentrante con bloccaggio concentrico dall'esterno all'interno e viceversa e in morsa doppia tramite la semplice sostituzione delle ganasce sul corpo base universale.

Possibility to transform each single vise in a self-centering vise with possibility to block from outside to inside and viceversa and in a double vise through the simple substitution of the jaws on the universal vise body base



### Altissima Rigidità Highest Rigidity

Base della morsa con una sezione doppia per garantire una maggiore rigidità. Flessioni ridotte di due volte rispetto alle normali morse modulari standard. Disponibili cubi monoblocco.

Higher vise base in order to guarantee a better rigidity. Bending reduced two times with respect to the Standard modular vises. Available solid vise towers.

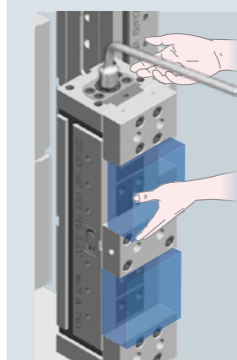

### Sistema a terza mano Third Hand service

Consente il carico e serraggio lieve del primo pezzo mentre le frattappe viene caricato il secondo di dimensione maggiore. Molto utile con l'utilizzo verticale della morsa

It allows the first workpiece loaded to be clamped lightly while the second workpiece is being loaded. Such device is useful especially with the vise vertically positioned.



### Vite a doppio filetto e slitte guidate

*Double thread spindle & guided slides*

Vite principale (completamente protetta) con filetto destro e sinistro e slitte lunghe quanto il corpo base con più chiavette per ganasce mobili

Completely protected main spindle with left and right thread and slides long as the vise base with multiple movable jaw positions



### Chiavette di Posizionamento Positioning Keyways

Chiavette longitudinali e trasversali sia sulla base per posizionamento orizzontale, che in testa per posizionamento verticale

Longitudinal and cross keyways both on the base bottom surface for horizontal positioning and on the side for vertical positioning



### Riconfigurazione Rapidissima Quickest Vise Resetting

Ganasce con piastre discendenti a cambio rapido manuale  
Pull down jaw plates with comb system (quick hand change)

# Staffe di ancoraggio / Vise holding clamps NEW 22/23

## FMS

**Coppia staffe di fissaggio Art.296, complete di vite e dado a "T"**  
Pair of vise holding clamps Art.296 complete of screw and "T" nuts



**Esempio d'ordine per morsa tipo 3 su macchina con cave a T da 18mm: Art.296 T.3 X=18mm**

**Oppure con codice: 2.29.6300 X=18mm**

Order example for Type 3 vise on machine with 18mm T-slots: **Art.296 T.3 X=18mm**

Also with code: **2.29.6300 X=18mm**

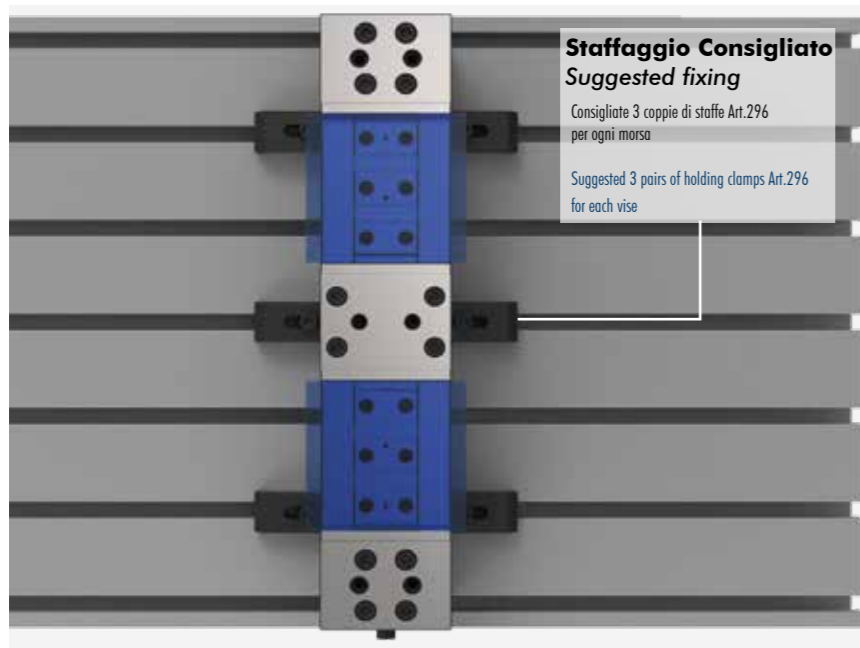

**Staffaggio Consigliato**  
Suggested fixing

Consigliate 3 coppie di staffe Art.296 per ogni morsa

Suggested 3 pairs of holding clamps Art.296 for each vise

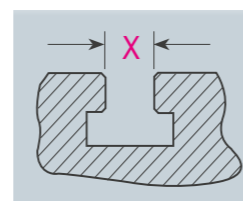

**Cava a T**

**T Slot**

Specificare sempre la cava della vostra macchina

Always specify the machine T-slot dimension

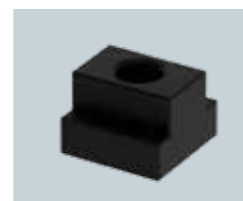

**Art.287** (Pag.4.34)

**Dadi a T - T Nuts**

Per fissaggio morsa alle cave a T della macchina

For vise clamping on the machine T-slots

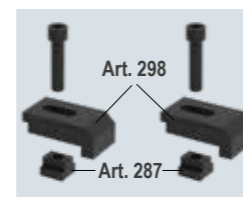

**Art.296**

(Art.298 + Art.287)

Consigliate 3 coppie di staffe Art.296 per ogni morsa

Suggested 3 pairs of holding clamps Art.296 for each vise

Tipo (grandezza) Type (size)	1				1				2 - 3				4 - 5 - 6									
<b>Art. 296</b>	12	14	16	18	12*	14	16	18	12*	14	16	18*	20	22	16	18	20	22	18*	20	22	
T-nuts Ref. N°	8	9	10	11	12	13	14	20	21	22	32	39	40	20	21	22	23	32	39	40	20	
Filetto vite Screw thread	<b>M8</b>				<b>M10</b>				<b>M12*</b>				<b>M16</b>									
<b>1 X M8</b>	A	50	50	50	50	50	50	50	76	76	76	76	86	86	86	86	86	86	86	86	86	
	B	24	24	24	24	24	24	24	30	30	30	30	40	40	40	40	40	40	40	40	40	
	C	6	6	6	6	6	6	6	6	6	6	6	10	10	10	10	10	10	10	10	10	
	ØD	8,5	11	13	17	13	17	13	17	13	17	13	17	13	17	13	17	13	17	13	17	
	E	10	10	10	10	10	10	10	13	13	13	13	15	15	15	15	15	15	15	15	15	
	ØF	14	-	-	-	-	-	-	-	-	-	-	-	-	-	-	-	-	-	-	-	
	G / G1	14	16/15	17,5/13	19/9	17/22	16/15	26/27	26/27	26/27	26/27	26/27	26/27	26/27	26/27	26/27	26/27	26/27	26/27	26/27	26/27	
	H	34	34	34	34	42	42	50	50	50	50	50	50	50	50	50	50	50	50	50	50	
	I	8	10	10	10	-	-	-	-	-	-	-	-	-	-	-	-	-	-	-	-	
	J	4	4	4	4	10	10	10	10	10	10	10	10	10	10	10	10	10	10	10	10	
	T ± 0,1	15	15	15	15	20	20	26	26	26	26	26	26	26	26	26	26	26	26	26	26	
	Cod.	2.29.61000 / M8	2.29.61000 / M10	2.29.61000 / M12	2.29.61000 / M16	2.29.63000 / M12	2.29.63000 / M12	2.29.65000 / M12	2.29.65000 / M16													

\* Scelta consigliata - Suggested choice

\* Scelta NON consigliata - NO Suggested choice

# Soluzioni personalizzate / Customized solutions

## FMS

**Soluzioni personalizzate a tutti i vostri problemi di serraggio**  
Customized solutions for all your clamping problems

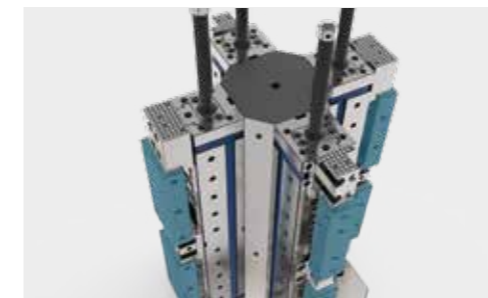

**Morse FMS automatizzate in verticale**

FMS vises automated vertically mounted

**Gestione automatica di morsa meccaniche grazie alla predisposizione per connessione con il robot. Lavorazioni del particolare su 3 lati con un unico serraggio evitando il riposizionamento ed una seconda ripresa del particolare da lavorare.**

Automated machine setting thanks to the pre-fitting with robot connection. Workpiece machining on 3 sides with one clamping and so avoiding re-positioning and a second machining of the workpiece.

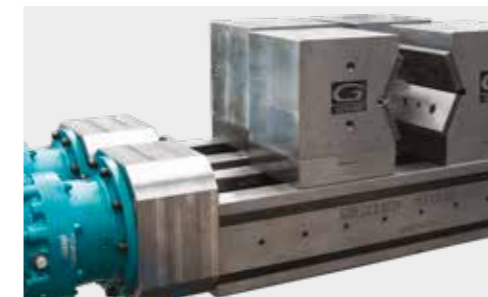

**Morsa FMS con riduttore epicicloidale**

FMS vise with epicyclic force reducer

**Riduttore epicicloidale il quale consente di moltiplicare notevolmente la coppia sviluppata dal motore idraulico consentendo di arrivare a elevate forze di serraggio, fino a 480 kN**

Epicyclic force reducer able to multiply greatly the torque generated by the hydraulic engine reaching a very high clamping force, maximum 480kN.



**Serraggio automatico di grandi particolari tondi**

Round workpieces automatic clamping

**Sistema di serraggio meccanico con morsa FMS per il serraggio di particolari tondi di grandi dimensioni controllato tramite centralina idraulica da CNC**

Quick positioning and clamping with FMS vises of whole equipment on round Zero Point plate through pull-studs and centering pin.



**Non solo per centri a 5 assi**

Not only for 5th axis machines

**Morsa autocentrante FMS su centro di lavoro verticale con ganasce personalizzate in alluminio.**

Self Centering FMS vise with taylor made jaws aluminum mounted on Vertical CNC



**Morse FMS in verticale con robot**

FMS vises vertically mounted + robot

**Assieme di morsa FMS montate verticalmente su centro orizzontale gestite tramite robot anche per carico e scarico pezzi**

FMS vises vertically mounted on horizontal machining center. Both vise clamping and workpieces turnover are operated through automated robotic system.

# TRE MORSE IN UNA THREE VISES IN ONE



Acquista il modulo base universale. Una soluzione aperta per il lavoro di oggi pensando a quello di domani !  
Buy the base body. A Versatile solution for present and future machining !

## CORPO BASE Art.855

## BASE BODY Art.855

Modulo base universale  
CENTINAIA DI GANASCE DISPONIBILI !!

Universal vise body module  
HUNDREDS OF JAWS AVAILABLE !!

## SERRAGGI SINGOLI

## SINGLE CLAMPING

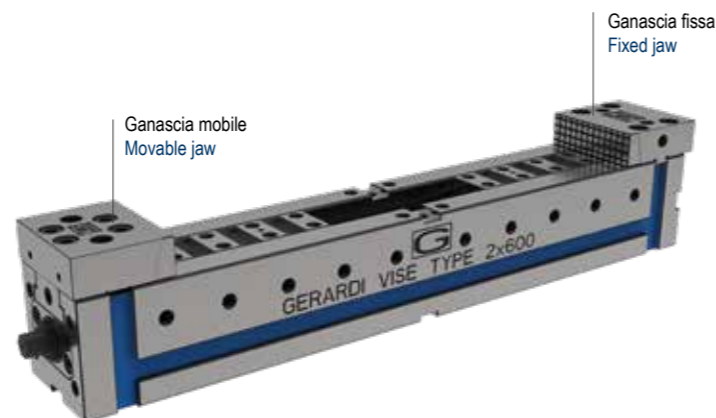
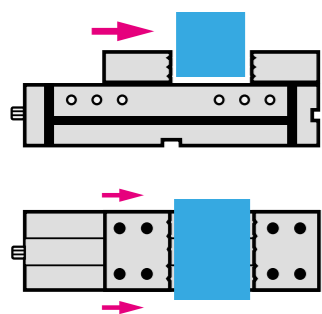

## SERRAGGI DOPPI

## DOUBLE CLAMPING

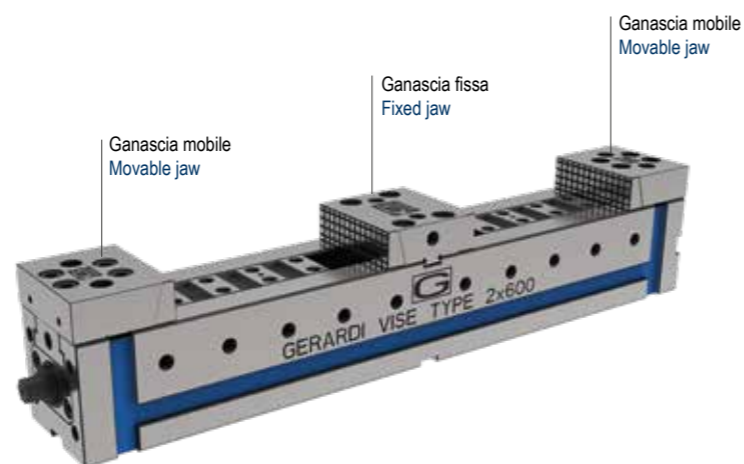
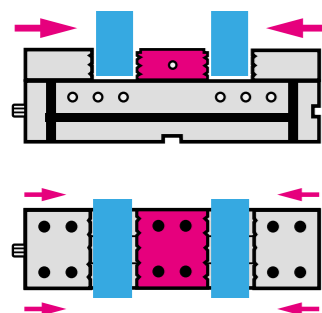

## AUTOCENTRANTE

## SELF-CENTERING

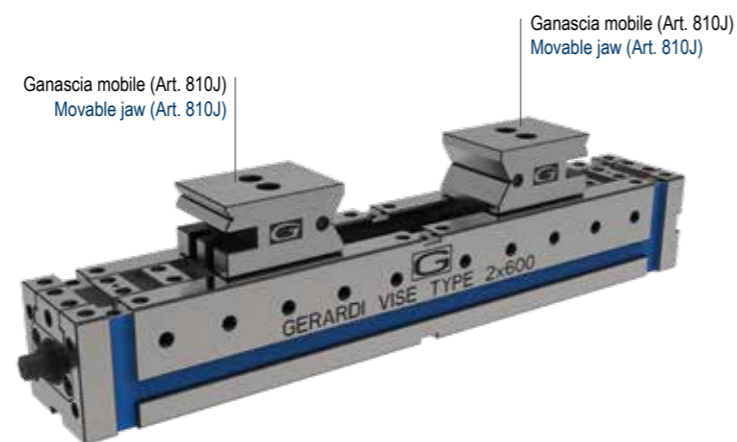
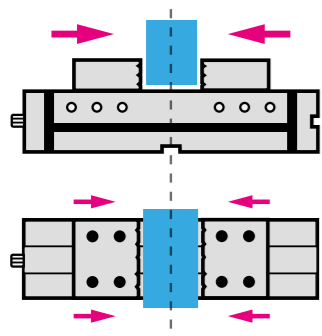

## VERSIONI PER SERRAGGI DOPPI

## DOUBLE CLAMPING CONFIGURATION

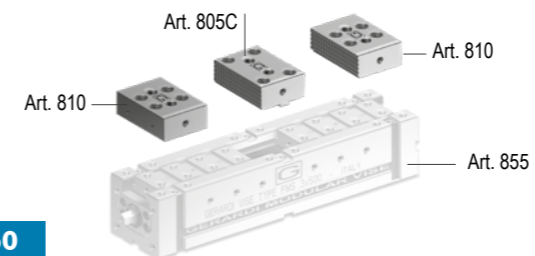

Art. 860

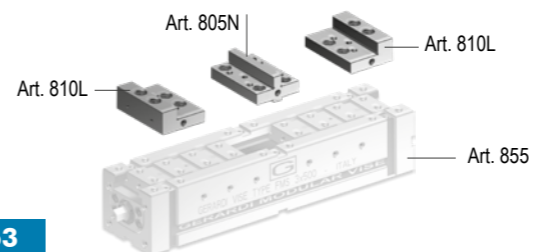

Art. 863

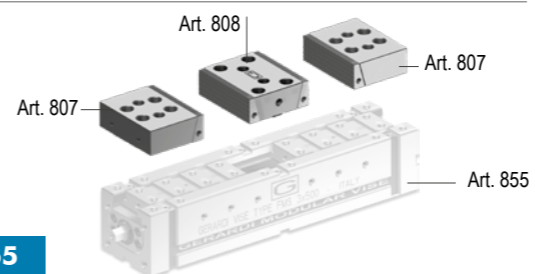

Art. 865

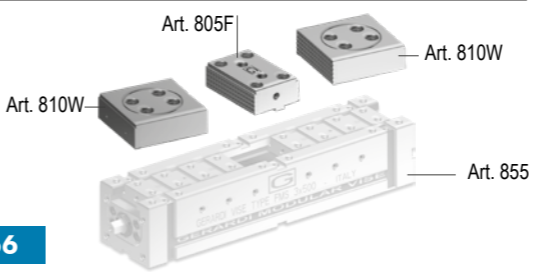

Art. 866

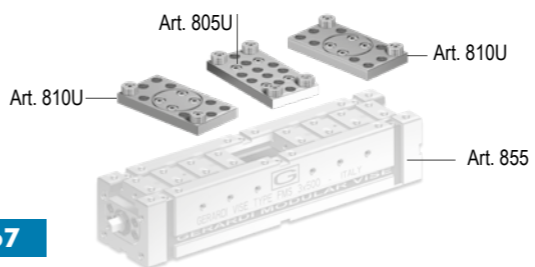

Art. 867

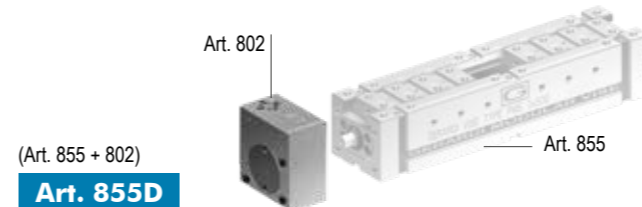

Art. 855D

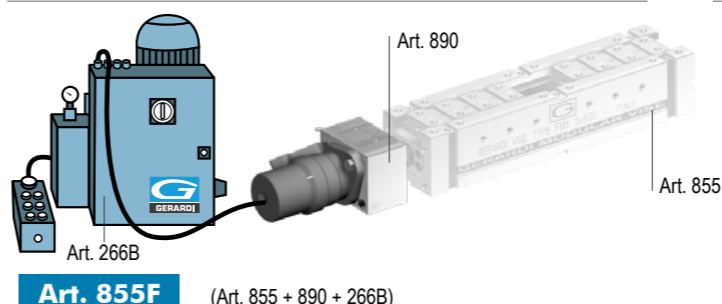

Art. 855F

## VERSIONI AUTOCENTRANTI

## SELF-CENTERING TYPE

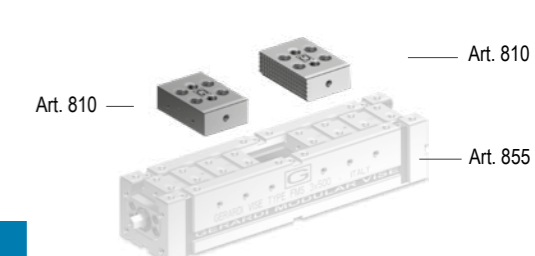

Art. 860

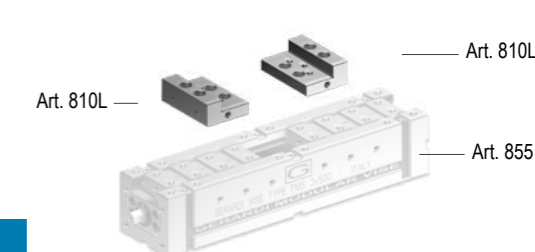

Art. 863

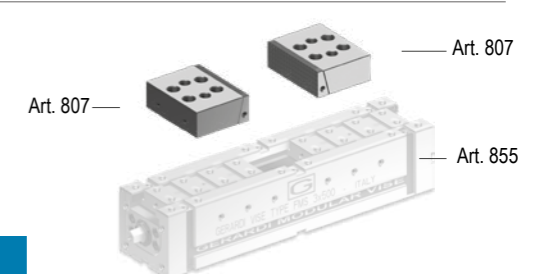

Art. 865

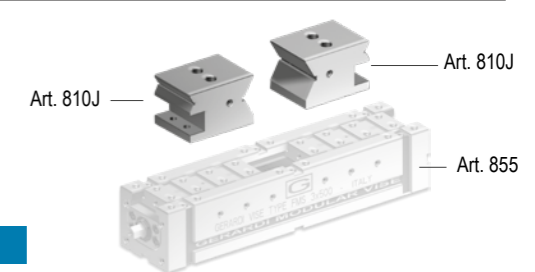

Art. 870

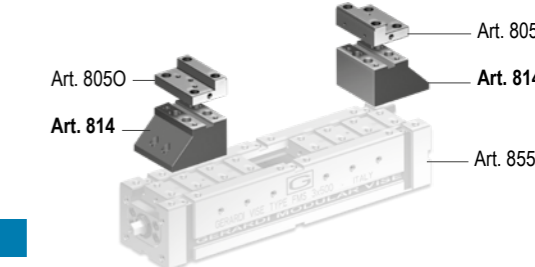

Art. 868

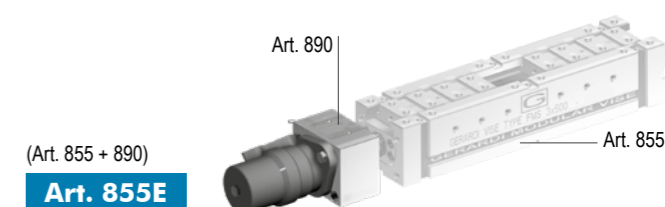

Art. 855E

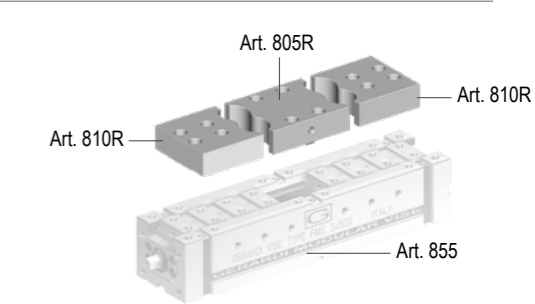

## CUBI DI MORSE MONTATI A CROCE O DORSO A DORSO VISE TOWERS CROSS OR BACK TO BACK MOUNTED

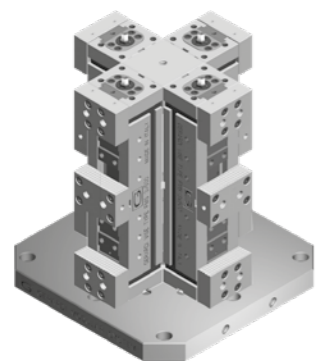

**N° 4 MORSE FMS**  
montate a croce su piastra base (Art. 827A)  
con distanziali (Art. 835)

**N° 4 FMS VISES**  
cross-mounted on base plate (Art. 827A)  
with spacers (Art. 835)

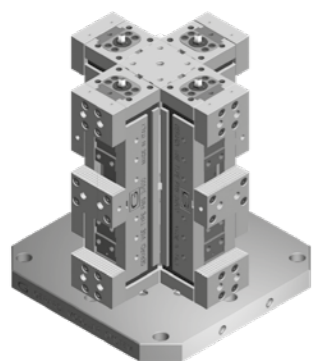

**N° 4 MORSE FMS**  
montate a croce su piastra base (Art. 827A)  
con supporto centrale (Art.836)

**N° 4 FMS VISES**  
cross-mounted on base plate (Art.827A)  
with center support (Art.836)

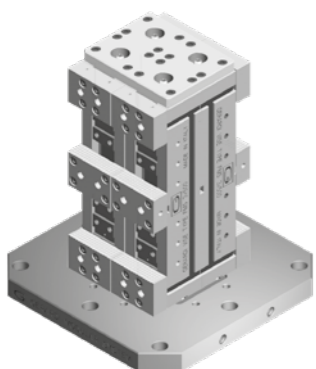

**N° 4 MORSE FMS**  
montate dorso a dorso, fianco a fianco, su piastra base  
(Art. 827) con piastra di collegamento (Art. 832)

**N° 4 FMS VISES**  
cross-mounted back-to-back, side by side, on base  
plate (Art. 827) with connecting plate (Art. 832)



**N° 4 MORSE FMS**  
montate dorso a dorso, su piastra base  
(Art. 827A) con piastra di collegamento (Art. 832)

**N° 4 FMS VISES**  
cross-mounted back-to-back, on base plate  
(Art. 827A) with connecting plate (Art. 832)

Montaggio ed allineamento morsa con distanziali, supporto centrale o piastra di collegamento  
Vise and alignment mounted with spacers, center support or connecting plate

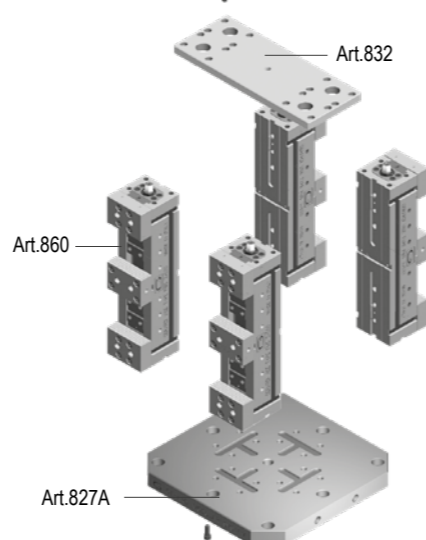
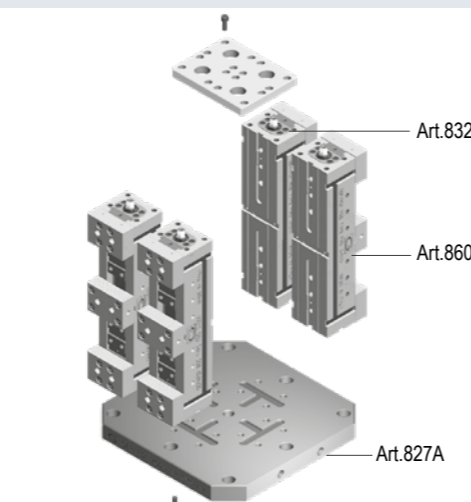
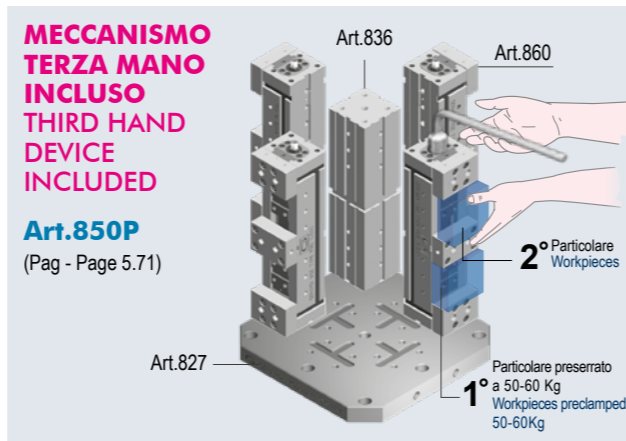
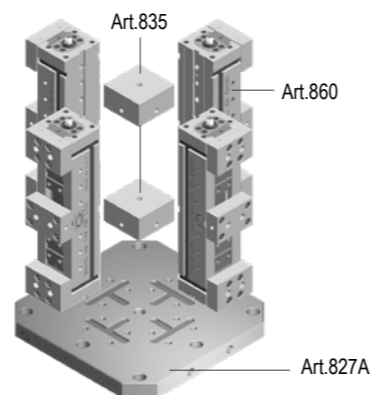

## CUBI DI MORSE MONTATI VERTICALMENTE VISE TOWERS VERTICALLY ASSEMBLED



**N° 3 morse FMS**  
montate verticalmente su piastra base a Y (827)  
con supporto centrale (Art. 838)

**N° 3 FMS vises**  
vises vertically mounted on Y base plate (827A)  
with exagon center support (Art. 838)

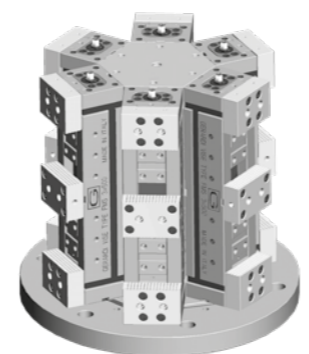

**N° 6 morse FMS**  
montate verticalmente su piastra base (Art. 827A)  
con distanziali esagonali (Art. 838)

**N° 6 FMS vises**  
vises vertically mounted on base plate (Art. 827A)  
with exagon spacer (Art. 838)

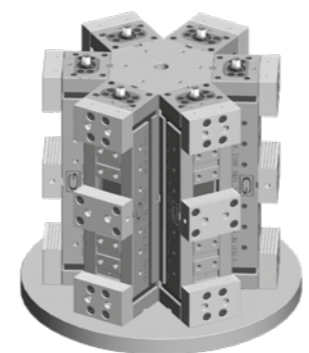

**N° 6 morse FMS** montate verticalmente  
su piastra base (Art. 827A)  
con supporto centrale (Art. 837)

**N° 6 FMS vises** vertically mounted  
on base plate (Art. 827A) with exagon  
center support (Art. 837)

Montaggio ed allineamento morsa con distanziali, supporto centrale o piastra di collegamento  
Vise and alignment mounted with spacers, center support or connecting plate

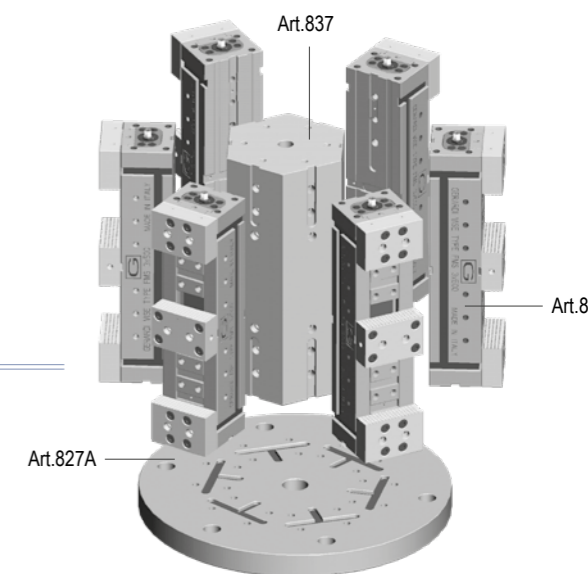
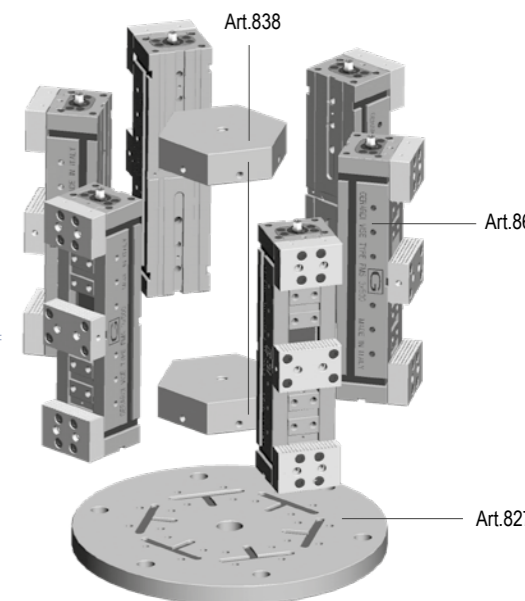
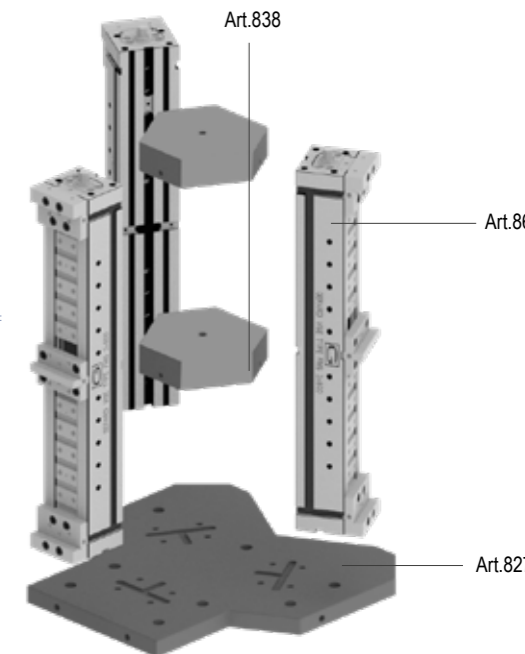

Tipo (grandezza) morsa / Vise type (size)		1 25 kN		2 25 kN			3 30 kN	
kN		25 kN		25 kN			30 kN	
Apertura massima fra le slitte / Maximum opening between slides	A	56	68	96	116	136	156	136
	C	70		90			100	
	D	200 + 32	300 + 32	300	400	500	600	400
	E	249	349	320	420	520	620	425
	G	75		95			125	
	R	74		94			124	
	S	69		89			99	
	T	72	116	102	142	182	222	132
	Y	277	377	360	460	560	660	470
	X	407	507	537	637	737	837	637
	kg	7	10	18	25	32	39	40
	Cod.	5.85.51200	5.85.51300	5.85.52300	5.85.52400	5.85.52500	5.85.52600	5.85.53400
								5.85.53500



**Art. 855D** (Art. 855 + 802) Morsa + moltiplicatore di coppia / Vise + torque multiplier

Cod.	5.85.5D120	5.85.5D130	5.85.5D230	5.85.5D240	5.85.5D250	5.85.5D260	5.85.5D340	5.85.5D350
------	------------	------------	------------	------------	------------	------------	------------	------------

Moltiplicatore di coppia con rinvio angolare - Mechanical with torque multiplier with angular transmission  
Chiave dinamometrica Art.357 (Consigliata) - Torque wrench Art.357 (Suggested)

Cod.	5.80.21000	5.80.22000	5.80.23000
------	------------	------------	------------

**Art. 855E** (Art. 855 + 890) Morsa + motore idraulico / Vise + hydraulic motor

Cod.	5.85.5E120	5.85.5E130	5.85.5E230	5.85.5E240	5.85.5E250	5.85.5E260	5.85.5E340	5.85.5E350
------	------------	------------	------------	------------	------------	------------	------------	------------

Meccanica con predisposizione elettroidraulica completa di motore, piastra, boccola e fincorsa

**Art. 855F** (Art. 855 + 890 + 266B) Morsa + motore idraulico + centralina / Vise + hydraulic motor + power unit

Cod.	5.85.5F120	5.85.5F130	5.85.5F230	5.85.5F240	5.85.5F250	5.85.5F260	5.85.5F340	5.85.5F350
------	------------	------------	------------	------------	------------	------------	------------	------------

Meccanica elettroidraulica completa di centralina idraulica apparecchiatura elettrica con pulsantiera

- Dotazione standard:
- 2 arresti laterali Art. 370
  - 1 coppia di tasselli di posizionamento per cava da 16 mm Art. 297
  - 1 chiave a pipa Art. 375

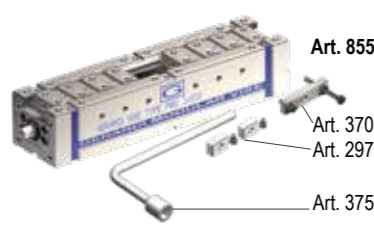

- Standard equipment:
- 2 workstops Art. 370
  - 1 pair of positioning key-nuts for 16 mm slot Art. 297
  - 1 box wrench Art. 375

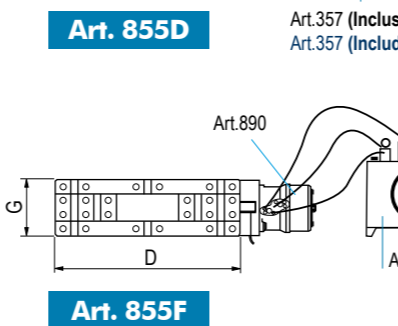
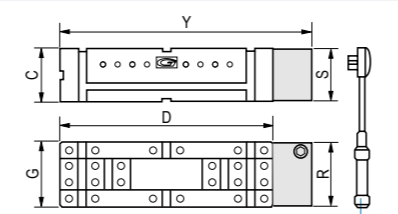
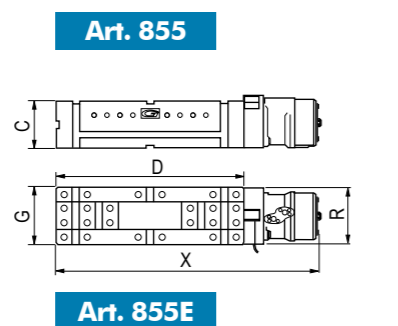
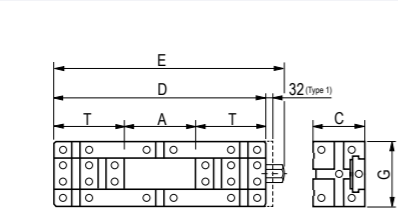

	3 30 kN			4 30 kN				5 32 kN			6 32 kN		
	30 kN			30 kN				32 kN			32 kN		
A	136	136	136	188	168	148	128	152	216	252	316	280	244
C	100			120				140			160		
D	600	700	800	500	600	700	800	600	700	800	800	900	1000
E	625	725	825	525	625	725	825	625	725	825	825	925	1025
G	125			145				170			190		
R	124			144				169			189		
S	99			119				139			159		
T	232	282	332	156	216	276	336	174	242	274	242	310	378
Y	670	770	870	570	670	770	870	-	-	-	-	-	-
X	837	937	1037	737	837	937	1037	837	937	1037	1037	1137	1237
kg	50	55	60	66	72	80	88	115	125	135	170	190	210
Cod.	5.85.53600	5.85.53700	5.85.53800	5.85.54500	5.85.54600	5.85.54700	5.85.54800	5.85.55600	5.85.55700	5.85.55800	5.85.56800	5.85.56900	5.85.56100

**Art. 855D** (Art. 855 + 802) Morsa + moltiplicatore di coppia / Vise + torque multiplier

Cod.	5.85.5D360	5.85.5D370	5.85.5D380	5.85.5D450	5.85.5D460	5.85.5D470	5.85.5D480	5.85.5D560	5.85.5D570	5.85.5D580	5.85.5D680	5.85.5D690	5.85.5D610
------	------------	------------	------------	------------	------------	------------	------------	------------	------------	------------	------------	------------	------------

Moltiplicatore di coppia con rinvio angolare - Mechanical with torque multiplier with angular transmission

Cod.	5.80.23000	5.80.24000	5.80.25000	5.80.26000
------	------------	------------	------------	------------

**Art. 855E** (Art. 855 + 890) Morsa + motore idraulico / Vise + hydraulic motor

Cod.	5.85.5E360	5.85.5E370	5.85.5E380	5.85.5E450	5.85.5E460	5.85.5E470	5.85.5E480	5.85.5E560	5.85.5E570	5.85.5E580	5.85.5E680	5.85.5E690	5.85.5E610
------	------------	------------	------------	------------	------------	------------	------------	------------	------------	------------	------------	------------	------------

Meccanica con predisposizione elettroidraulica completa di motore, piastra, boccola e fincorsa

**Art. 855F** (Art. 855 + 890 + 266B) Morsa + motore idraulico + centralina / Vise + hydraulic motor + power unit

Cod.	5.85.5F360	5.85.5F370	5.85.5F380	5.85.5F450	5.85.5F460	5.85.5F470	5.85.5F480	5.85.5F560	5.85.5F570	5.85.5F580	5.85.5F680	5.85.5F690	5.85.5F610
------	------------	------------	------------	------------	------------	------------	------------	------------	------------	------------	------------	------------	------------

Meccanica elettroidraulica completa di centralina idraulica apparecchiatura elettrica con pulsantiera

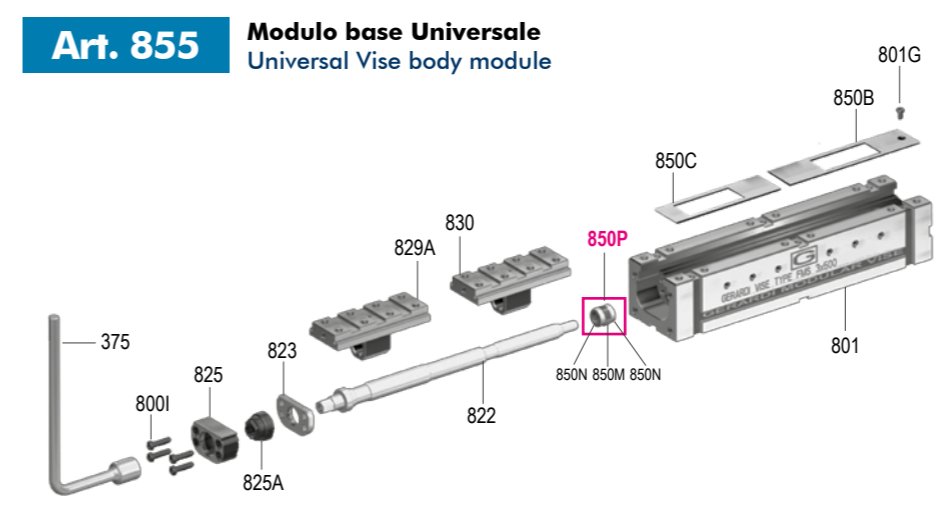

Art.	Pag.	Art.	Pag.
375	4.35	850C	5.61
800I	5.61	850P	5.72
801G	5.61	-	-
801I	5.61	-	-
822	5.53	-	-
823	5.59	-	-
825	5.59	-	-
825A	5.61	-	-
829A	5.52	-	-
830	5.52	-	-
850B	5.61	-	-

Tipo (grandezza) morsa / Vise type (size)	kN	1 25 kN		2 25 kN				3 30 kN	
Apertura massima / Maximum opening	A	2 x 16	2 x 66	2 x 54	2 x 104	2 x 154	2 x 204	2 x 74	2 x 124
<b>Art. 860</b> Morsa FMS doppia, singola, autocentrante con ganasce zigrinate	B	25			30			40	
	C	70			90			100	
	D	232	332	300	400	500	600	400	500
	E	249	349	320	420	520	620	425	525
	G	75			95			125	
	J	56			64			84	
	W	74			94			124	
	kg	9	12	22	29	35	42	44	49
	Cod.	5.86.01200	5.86.01300	5.86.02300	5.86.02400	5.86.02500	5.86.02600	5.86.03400	5.86.03500



Double, single, self-centering FMS vise with serrated jaws

**Art. 860D** (Art. 860 + 802) Morsa + moltiplicatore di coppia / Vise + torque multiplier

Cod.	5.86.0D120	5.86.0D130	5.86.0D230	5.86.0D240	5.86.0D250	5.86.0D260	5.86.0D340	5.86.0D350
------	------------	------------	------------	------------	------------	------------	------------	------------

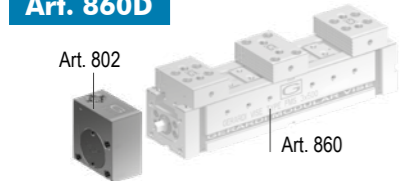

Moltiplicatore di coppia con rinvio angolare - Mechanical with torque multiplier with angular transmission

Chiave dinamometrica Art.357 (Consigliata) - Torque wrench Art.357 (Suggested)

Cod.	5.80.21000	5.80.22000	5.80.23000
------	------------	------------	------------

**Art. 802**

Cod.	5.80.21000	5.80.22000	5.80.23000
------	------------	------------	------------

**Art. 860E** (Art. 860 + 890) Morsa + motore idraulico / Vise + hydraulic motor

Cod.	5.86.0E120	5.86.0E130	5.86.0E230	5.86.0E240	5.86.0E250	5.86.0E260	5.86.0E340	5.86.0E350
------	------------	------------	------------	------------	------------	------------	------------	------------

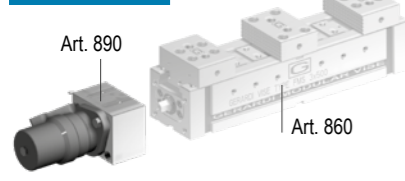

**Art. 860F** (Art. 860 + 890 + 266B) Morsa + motore idraulico + centralina / Vise + hydraulic motor + power unit

Cod.	5.86.0F120	5.86.0F130	5.86.0F230	5.86.0F240	5.86.0F250	5.86.0F260	5.86.0F340	5.86.0F350
------	------------	------------	------------	------------	------------	------------	------------	------------

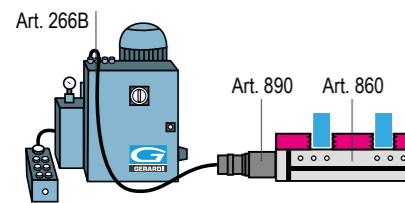

- Dotazione standard:
- 2 arresti laterali Art. 370
  - 1 coppia di tasselli di posizionamento per cava da 16 mm Art. 297
  - 1 chiave a pipa Art. 375

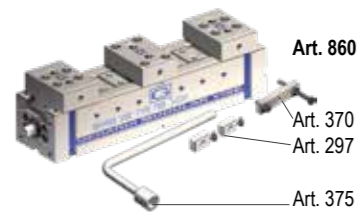

- Standard equipment:
- 2 workstops Art. 370
  - 1 pair of positioning key-nuts for 16 mm slot Art. 297
  - 1 box wrench Art. 375

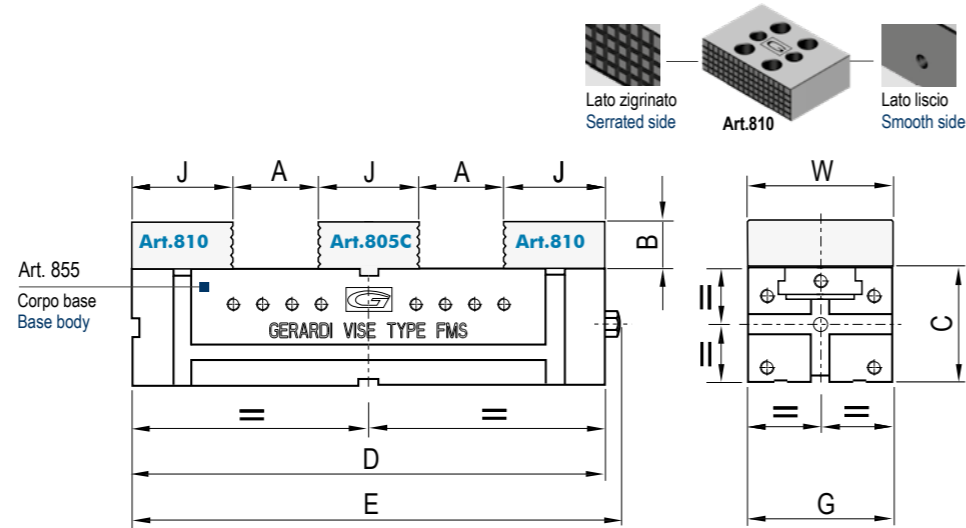

	3 30 kN			4 30 kN				5 32 kN			6 32 kN		
A	2 x 174	2 x 224	2 x 274	2 x 103	2 x 153	2 x 203	2 x 253	2 x 138	2 x 188	2 x 238	2 x 238	2 x 288	2 x 338
B	40			50				60				60	
C	100			120				140				160	
D	600	700	800	500	600	700	800	600	700	800	800	900	1000
E	625	725	825	525	625	725	825	625	725	825	825	925	1025
G	125			145				170				190	
J	84			98				108				108	
W	124			144				169				189	
kg	54	59	64	71	79	88	96	130	140	150	210	230	250
Cod.	5.86.03600	5.86.03700	5.86.03800	5.86.04500	5.86.04600	5.86.04700	5.86.04800	5.86.05600	5.86.05700	5.86.05800	5.86.06800	5.86.06900	5.86.06100

**Art. 860D** (Art. 860 + 802) Morsa + moltiplicatore di coppia / Vise + torque multiplier

Cod.	5.86.0D360	5.86.0D370	5.86.0D380	5.86.0D450	5.86.0D460	5.86.0D470	5.86.0D480	5.86.0D560	5.86.0D570	5.86.0D580	5.86.0D680	5.86.0D690	5.86.0D610
------	------------	------------	------------	------------	------------	------------	------------	------------	------------	------------	------------	------------	------------

**Art. 802** Moltiplicatore di coppia con rinvio angolare - Mechanical with torque multiplier with angular transmission

Cod.	5.80.23000	5.80.24000	5.80.25000	5.80.26000
------	------------	------------	------------	------------

**Art. 860E** (Art. 860 + 890) Morsa + motore idraulico / Vise + hydraulic motor

Cod.	5.86.0E360	5.86.0E370	5.86.0E380	5.86.0E450	5.86.0E460	5.86.0E470	5.86.0E480	5.86.0E560	5.86.0E570	5.86.0E580	5.86.0E680	5.86.0E690	5.86.0E610
------	------------	------------	------------	------------	------------	------------	------------	------------	------------	------------	------------	------------	------------

**Art. 860F** (Art. 860 + 890 + 266B) Morsa + motore idraulico + centralina / Vise + hydraulic motor + power unit

Cod.	5.86.0F360	5.86.0F370	5.86.0F380	5.86.0F450	5.86.0F460	5.86.0F470	5.86.0F480	5.86.0F560	5.86.0F570	5.86.0F580	5.86.0F680	5.86.0F690	5.86.0F610
------	------------	------------	------------	------------	------------	------------	------------	------------	------------	------------	------------	------------	------------

**Art. 860 Esempi applicativi ganasce:**  
Jaw application examples:

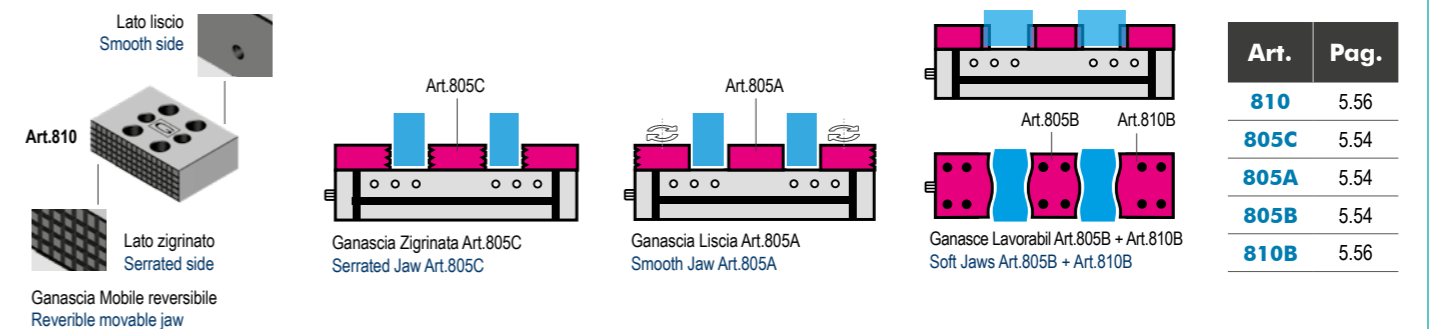

Art.	Pag.
810	5.56
805C	5.54
805A	5.54
805B	5.54
810B	5.56



Tipo (grandezza) morsa / Vise type (size)	kN	1 25 kN		2 25 kN				3 30 kN	
Apertura massima / Maximum opening	A	2 x 60	2 x 110	2 x 118	2 x 168	2 x 218	2 x 268	2 x 162	2 x 212
	B	25			30			40	
	C	70			90			100	
	D	232	332	300	400	500	600	400	500
	E	249	349	320	420	520	620	425	525
	G	75			95			125	
	J	56			64			84	
	J1	22			24			30	
	J2	16			16			16	
	W	74			94			124	
	kg	8	11	20	27	33	40	40	45
	Cod.	5.86.31200	5.86.31300	5.86.32300	5.86.32400	5.86.32500	5.86.32600	5.86.33400	5.86.33500

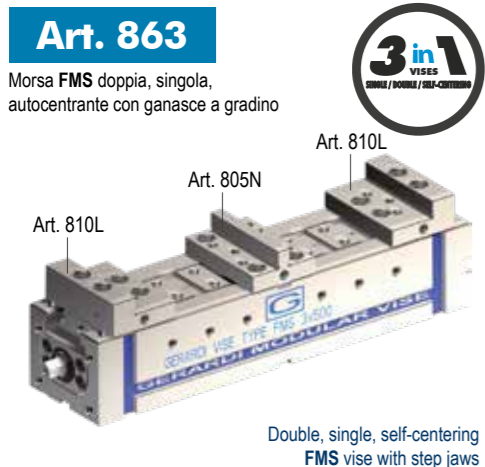

**Art. 863D** (Art. 863 + 802) Morsa + moltiplicatore di coppia / Vise + torque multiplier

Cod.	5.86.3D120	5.86.3D130	5.86.3D230	5.86.3D240	5.86.3D250	5.86.3D260	5.86.3D340	5.86.3D350
------	------------	------------	------------	------------	------------	------------	------------	------------

**Art. 802** Moltiplicatore di coppia con rinvio angolare - Mechanical with torque multiplier with angular transmission

Chiave dinamometrica Art.357 (Consigliata) - Torque wrench Art.357 (Suggested)

Cod.	5.80.21000	5.80.22000	5.80.23000
------	------------	------------	------------

**Art. 863E** (Art. 863 + 890) Morsa + motore idraulico / Vise + hydraulic motor

Cod.	5.86.3E120	5.86.3E130	5.86.3E230	5.86.3E240	5.86.3E250	5.86.3E260	5.86.3E340	5.86.3E350
------	------------	------------	------------	------------	------------	------------	------------	------------

**Art. 863F** (Art. 863 + 890 + 266B) Morsa + motore idraulico + centralina / Vise + hydraulic motor + power unit

Cod.	5.86.3F120	5.86.3F130	5.86.3F230	5.86.3F240	5.86.3F250	5.86.3F260	5.86.3F340	5.86.3F350
------	------------	------------	------------	------------	------------	------------	------------	------------

Dotazione standard:  
 ■ 2 arresti laterali Art. 370  
 ■ 1 coppia di tasselli di posizionamento per cava da 16 mm Art. 297  
 ■ 1 chiave a pipa Art. 375

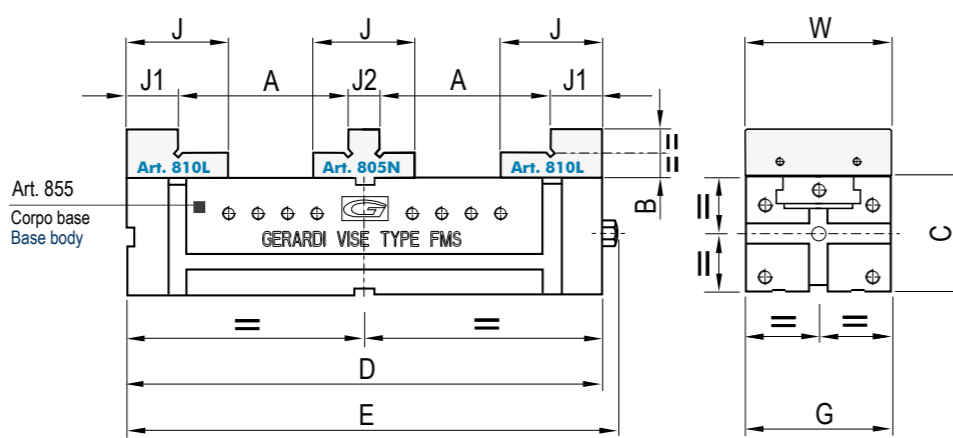
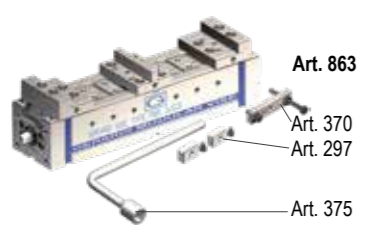

Standard equipment:  
 ■ 2 workstops Art. 370  
 ■ 1 pair of positioning key-nuts for 16 mm slot Art. 297

	3 30 kN			4 30 kN				5 32 kN			6 32 kN		
A	2 x 262	2 x 312	2 x 362	2 x 204	2 x 254	2 x 304	2 x 354	2 x 254	2 x 304	2 x 354	2 x 354	2 x 404	2 x 454
B	40			50				60				60	
C	100			120				140				160	
D	600	700	800	500	600	700	800	600	700	800	800	900	1000
E	625	725	825	525	625	725	825	625	725	825	825	925	1025
G	125			145				170				190	
J	84			98				108				108	
J1	30			38				38				38	
J2	16			16				16				16	
W	124			144				169				189	
kg	50	55	60	68	76	85	93	124	134	144	200	220	240
Cod.	5.86.33600	5.86.33700	5.86.33800	5.86.34500	5.86.34600	5.86.34700	5.86.34800	5.86.35600	5.86.35700	5.86.35800	5.86.36800	5.86.36900	5.86.36100

**Art. 863D** (Art. 863 + 802) Morsa + moltiplicatore di coppia / Vise + torque multiplier

Cod.	5.86.3D360	5.86.3D370	5.86.3D380	5.86.3D450	5.86.3D460	5.86.3D470	5.86.3D480	5.86.3D560	5.86.3D570	5.86.3D580	5.86.3D680	5.86.3D690	5.86.3D610
------	------------	------------	------------	------------	------------	------------	------------	------------	------------	------------	------------	------------	------------

**Art. 802** Moltiplicatore di coppia con rinvio angolare - Mechanical with torque multiplier with angular transmission

Cod.	5.80.23000	5.80.24000	5.80.25000	5.80.26000
------	------------	------------	------------	------------

**Art. 863E** (Art. 863 + 890) Morsa + motore idraulico / Vise + hydraulic motor

Cod.	5.86.3E360	5.86.3E370	5.86.3E380	5.86.3E450	5.86.3E460	5.86.3E470	5.86.3E480	5.86.3E560	5.86.3E570	5.86.3E580	5.86.3E680	5.86.3E690	5.86.3E610
------	------------	------------	------------	------------	------------	------------	------------	------------	------------	------------	------------	------------	------------

**Art. 863F** (Art. 863 + 890 + 266B) Morsa + motore idraulico + centralina / Vise + hydraulic motor + power unit

Cod.	5.86.3F360	5.86.3F370	5.86.3F380	5.86.3F450	5.86.3F460	5.86.3F470	5.86.3F480	5.86.3F560	5.86.3F570	5.86.3F580	5.86.3F680	5.86.3F690	5.86.3F610
------	------------	------------	------------	------------	------------	------------	------------	------------	------------	------------	------------	------------	------------

**Art. 863 Esempi applicativi ganasce:**  
Jaw application examples:

Art. 512: Serraggio simultaneo di 4 pezzi con ganascia intermedia / 4 Workpieces simultaneous clamping with intermediate jaw

Tipo (grandezza) morsa / Vise type (size)	kN	1 25 kN		2 25 kN				3 30 kN	
Apertura massima / Maximum opening	A	2 x 32	2 x 82	2 x 54	2 x 104	2 x 154	2 x 204	2 x 77	2 x 127
<b>Art. 864</b>	A1	2 x 84	2 x 134	2 x 118	2 x 168	2 x 218	2 x 268	2 x 162	2 x 212
Morsa FMS doppia, singola, autocentrante con ganasce a DOPPIO gradino	B	25		30				40	
	C	70		90				100	
	D	232	332	300	400	500	600	400	500
	E	249	349	320	420	520	620	425	525
	G	75		95				125	
	J	56		64				84	
	J1	24		24				30	
	J2	16		16				16	
	W	74		94				124	
kg		8	11	20	27	33	40	40	45
Cod.		5.86.41200	5.86.41300	5.86.42300	5.86.42400	5.86.42500	5.86.42600	5.86.43400	5.86.43500

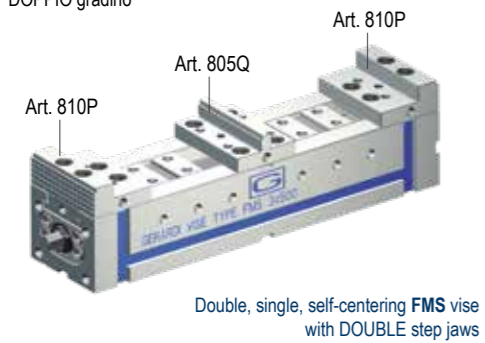

**Art. 805F**  
Ganascia fissa con doppio gradino 3x5 LISCIA  
Fixed jaw with double 3x5 step SMOOTH

Cod.	5.80.5F100	5.80.5F200	5.80.5F300
------	------------	------------	------------



**Art. 805G**  
Ganascia fissa con doppio gradino 3x5 ZIGRINATA  
Fixed jaw with double 3x5 step SERRATED

Cod.	5.80.5G100	5.80.5G200	5.80.5G300
------	------------	------------	------------



**Art. 810O**  
Ganascia mobile con gradino piccolo e grande  
Movable jaw with small and large step

Cod.	5.81.0O100	5.81.0O200	5.81.0O300
------	------------	------------	------------

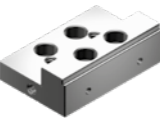

**Art. 810X**  
Ganascia mobile oscillante con gradino 3x5 zigrinata da un lato con albero a gradino (Art. 810Z)  
Floating movable jaw with 3x5 step one side serrated with step block pin (Art. 810Z)

Cod.	5.81.0X100	5.81.0X200	5.81.0X300
------	------------	------------	------------

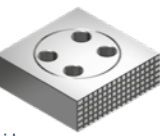

- Dotazione standard:
- 2 arresti laterali Art. 370
  - 1 coppia di tasselli di posizionamento per cava da 16 mm Art. 297
  - 1 chiave a pipa Art. 375

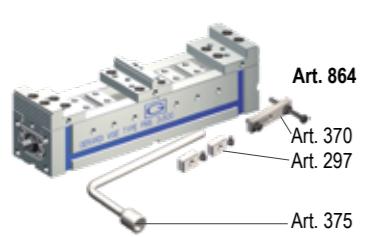

- Standard equipment:
- 2 workstops Art. 370
  - 1 pair of positioning key-nuts for 16 mm slot Art. 297
  - 1 box wrench Art. 375

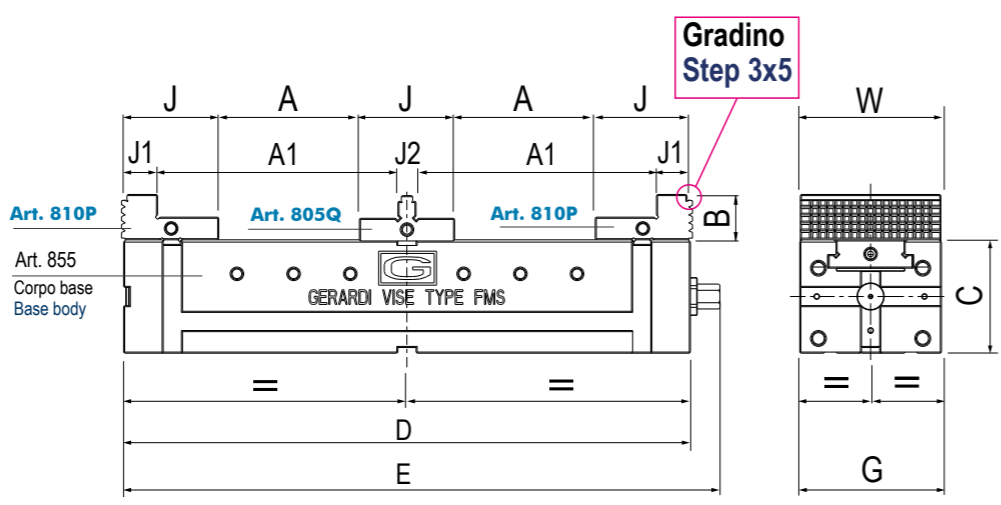

	3 30 kN			4 30 kN				5 32 kN			6 32 kN		
A	2 x 177	2 x 227	2 x 277	2 x 103	2 x 153	2 x 203	2 x 253	2 x 138	2 x 188	2 x 238	2 x 238	2 x 288	2 x 338
A1	2 x 262	2 x 312	2 x 362	2 x 204	2 x 254	2 x 304	2 x 354	2 x 254	2 x 304	2 x 354	2 x 354	2 x 404	2 x 454
B	40			50				60			60		
C	100			120				140			160		
D	600	700	800	500	600	700	800	600	700	800	800	900	1000
E	625	725	825	525	625	725	825	625	725	825	825	925	1025
G	125			145				170			190		
J	84			98				108			108		
J1	30			38				38			38		
J2	16			16				16			16		
W	124			144				169			189		
kg	50	55	60	68	76	85	93	124	134	144	200	220	240
Cod.	5.86.43600	5.86.43700	5.86.43800	5.86.44500	5.86.44600	5.86.44700	5.86.44800	5.86.45600	5.86.45700	5.86.45800	5.86.46800	5.86.46900	5.86.46100

**Art. 805F**

Cod.	5.80.5F300	5.80.5F400	5.80.5F500	5.80.5F300
------	------------	------------	------------	------------

**Art. 805G**

Cod.	5.80.5G300	5.80.5G400	5.80.5G500	5.80.5G600
------	------------	------------	------------	------------

**Art. 810O**

Cod.	5.81.0O300	5.81.0O400	5.81.0O500	5.81.0O600
------	------------	------------	------------	------------

**Art. 810X**

Cod.	5.81.0X300	5.81.0X400	5.81.0X500	5.81.0X600
------	------------	------------	------------	------------

**Art. 864** Esempi applicativi ganasce a doppio gradino:  
Double step jaw application examples:

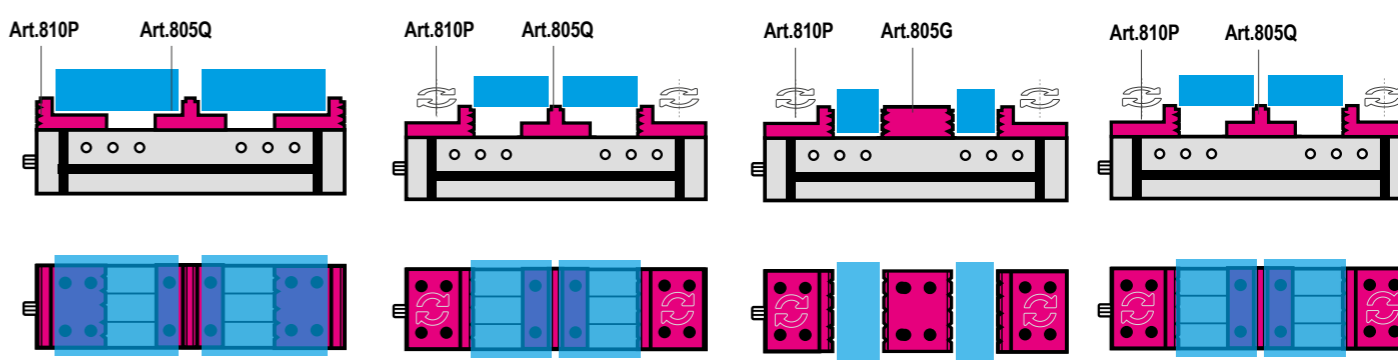

Utilizzo del gradino standard per alzare il particolare rispetto alla base  
Use the main step for raising the workpiece

Per utilizzare il 2° gradino (3x5) ruotare le ganasce mobili di 180°  
In order to use the second 3x5mm step turn the movable jaw 180°

Per sfruttare il lato zigrinato delle ganasce mobili Art.810P sostituisci la ganascia fissa centrale con l'Art.805G  
To exploit the serrated side of the movable jaws Art.810P change the fixed central jaw with Art.805G

Tipo (grandezza) morsa / Vise type (size)	kN	1 25 kN		2 25 kN				3 30 kN	
Apertura massima / Maximum opening	A	2 x 52		2 x 30	2 x 80	2 x 130	2 x 180	2 x 46	2 x 96
<b>Art. 865</b> Morsa FMS doppia, singola, autocentrante con ganasce a cambio rapido discendente (sistema a pettine)	B	25		30				40	
	C	70		90				100	
	D	332	300	400	500	600	400	500	
	E	349	320	420	520	620	425	525	
	G	75		95				125	
	J	63		76				98	
	J1	70		88				111	
	W	74		94				124	
	kg	12	23	30	36	43	46	51	
	Cod.	5.86.51300	5.86.52300	5.86.52400	5.86.52500	5.86.52600	5.86.53400	5.86.53500	

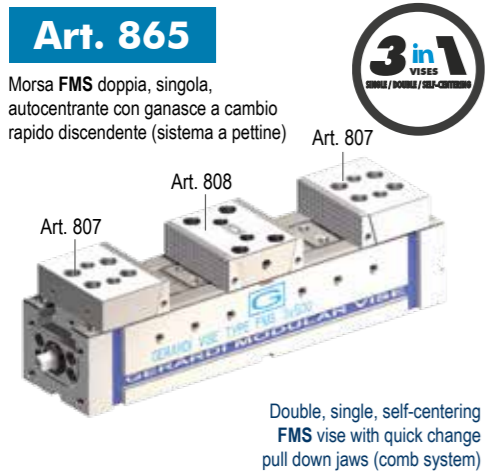

Double, single, self-centering FMS vise with quick change pull down jaws (comb system)

**Art. 865D** (Art. 865 + 802) Morsa + moltiplicatore di coppia / Vise + torque multiplier

Cod.	5.86.5D130	5.86.5D230	5.86.5D240	5.86.5D250	5.86.5D260	5.86.5D340	5.86.5D350
------	------------	------------	------------	------------	------------	------------	------------

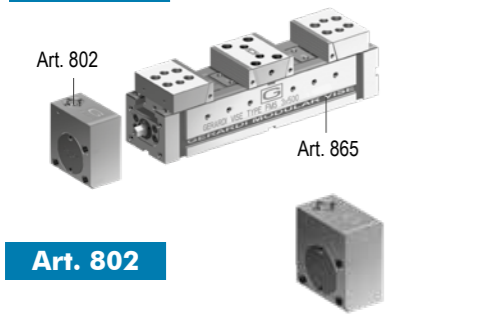

Moltiplicatore di coppia con rinvio angolare - Mechanical with torque multiplier with angular transmission  
Chiave dinamometrica Art.357 (Consigliata) - Torque wrench Art.357 (Suggested)

Cod.	5.80.21000	5.80.22000	5.80.23000
------	------------	------------	------------

**Art. 865E** (Art. 865 + 890) Morsa + motore idraulico / Vise + hydraulic motor

Cod.	5.86.5E130	5.86.5E230	5.86.5E240	5.86.5E250	5.86.5E260	5.86.5E340	5.86.5E350
------	------------	------------	------------	------------	------------	------------	------------

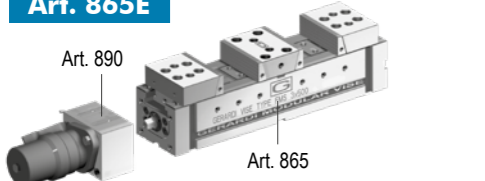

**Art. 865F** (Art. 865 + 890 + 266B) Morsa + motore idraulico + centralina / Vise + hydraulic motor + power unit

Cod.	5.86.5F130	5.86.5F230	5.86.5F240	5.86.5F250	5.86.5F260	5.86.5F340	5.86.5F350
------	------------	------------	------------	------------	------------	------------	------------

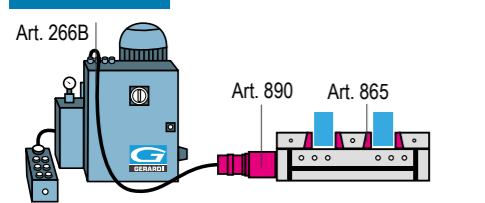

- Dotazione standard:
- 2 arresti laterali Art. 370
  - 1 coppia di tasselli di posizionamento per cava da 16 mm Art. 297
  - 1 chiave a pipa Art. 375

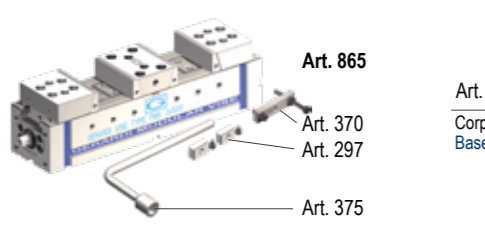

- Standard equipment:
- 2 workstops Art. 370
  - 1 pair of positioning key-nuts for 16 mm slot Art. 297
  - 1 box wrench Art. 375

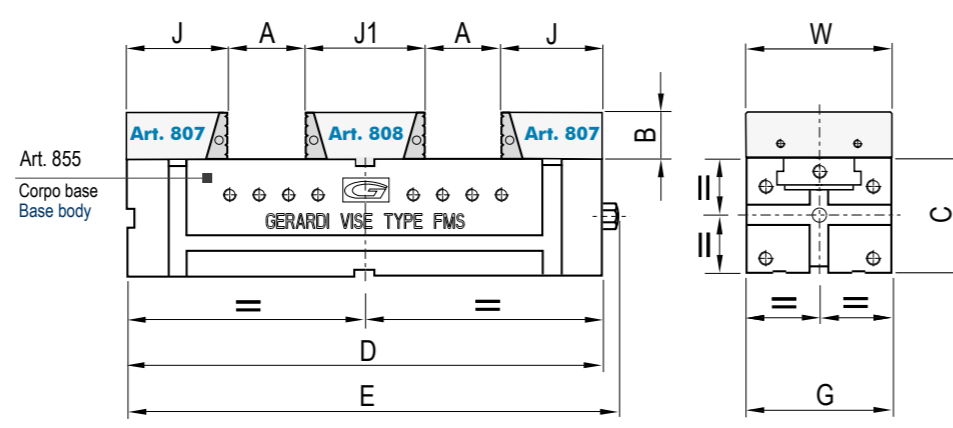

	3 30 kN			4 30 kN				5 32 kN			6 32 kN		
A	2 x 146	2 x 196	2 x 246	2 x 65	2 x 115	2 x 165	2 x 215	2 x 90	2 x 140	2 x 190	2 x 216	2 x 256	2 x 316
B	40			50				60			60		
C	100			120				140			160		
D	600	700	800	500	600	700	800	600	700	800	800	900	1000
E	625	725	825	525	625	725	825	625	725	825	825	925	1025
G	125			145				170			190		
J	98			117				132			119		
J1	111			136				155			130		
W	124			144				169			189		
kg	54	59	64	74	82	91	99	134	144	154	215	235	255
Cod.	5.86.53600	5.86.53700	5.86.53800	5.86.54500	5.86.54600	5.86.54700	5.86.54800	5.86.55600	5.86.55700	5.86.55800	5.86.56800	5.86.56900	5.86.56100

**Art. 865D** (Art. 865 + 802) Morsa + moltiplicatore di coppia / Vise + torque multiplier

Cod.	5.86.5D360	5.86.5D370	5.86.5D380	5.86.5D450	5.86.5D460	5.86.5D470	5.86.5D480	5.86.5D560	5.86.5D570	5.86.5D580	5.86.5D680	5.86.5D690	5.86.5D610
------	------------	------------	------------	------------	------------	------------	------------	------------	------------	------------	------------	------------	------------

**Art. 802** Moltiplicatore di coppia con rinvio angolare - Mechanical with torque multiplier with angular transmission

Cod.	5.80.23000	5.80.24000	5.80.25000	5.80.26000
------	------------	------------	------------	------------

**Art. 865E** (Art. 865 + 890) Morsa + motore idraulico / Vise + hydraulic motor

Cod.	5.86.5E360	5.86.5E370	5.86.5E380	5.86.5E450	5.86.5E460	5.86.5E470	5.86.5E480	5.86.5E560	5.86.5E570	5.86.5E580	5.86.5E680	5.86.5E690	5.86.5E610
------	------------	------------	------------	------------	------------	------------	------------	------------	------------	------------	------------	------------	------------

**Art. 865F** (Art. 865 + 890 + 266B) Morsa + motore idraulico + centralina / Vise + hydraulic motor + power unit

Cod.	5.86.5F360	5.86.5F370	5.86.5F380	5.86.5F450	5.86.5F460	5.86.5F470	5.86.5F480	5.86.5F560	5.86.5F570	5.86.5F580	5.86.5F680	5.86.5F690	5.86.5F610
------	------------	------------	------------	------------	------------	------------	------------	------------	------------	------------	------------	------------	------------

**Art. 865** Esempi applicativi piastre ganasce: Jaw plates application examples:

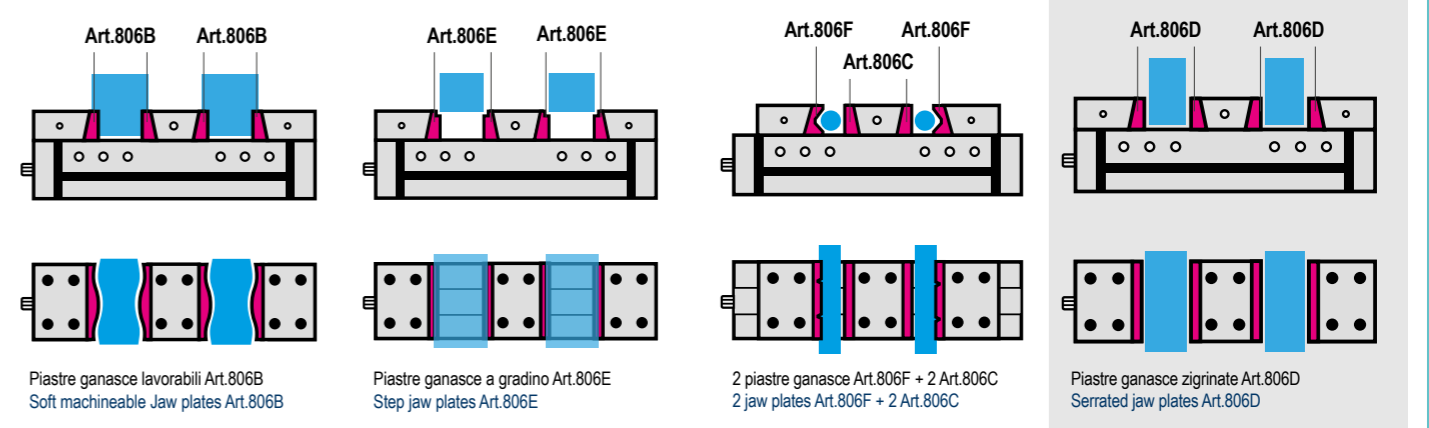

Configurazione standard / Standard configuration

Piastre ganasce lavorabili Art.806B Soft machineable Jaw plates Art.806B  
Piastre ganasce a gradino Art.806E Step jaw plates Art.806E  
2 piastre ganasce Art.806F + 2 Art.806C 2 jaw plates Art.806F + 2 Art.806C  
Piastre ganasce zigrinate Art.806D Serrated jaw plates Art.806D

**CORPI GANASCE FMS & PIASTRE GANASCE INTERCAMBIABILI RAPIDE**  
FMS COMB JAW BODIES & QUICK INTERCHANGEABLE JAW PLATES

Tipo (grandezza) / Type (size)	1	2	3	4	5	6
<b>Art. 806*</b> Ganascia fissa con piastra ganascia zigrinata intercambiabile rapida Fixed jaw with quick interchangeable serrated jaw plate	Cod. 5.80.61000	5.80.62000	5.80.63000	5.80.64000	5.80.65000	5.80.66000
<b>Art. 807*</b> Ganascia mobile con piastra ganascia zigrinata intercambiabile rapida Movable jaw with quick interchangeable serrated jaw plate	Cod. 5.80.71000	5.80.72000	5.80.73000	5.80.74000	5.80.75000	5.80.76000
<b>Art. 808*</b> Ganascia fissa doppia con piastre ganasce zigrinate intercambiabili rapide Double fixed jaw with quick interchangeable serrated jaw plate	Cod. 5.80.81000	5.80.82000	5.80.83000	5.80.84000	5.80.85000	5.80.86000
<b>Art. 806A</b> Corpo ganascia fissa per piastra ganascia intercambiabile rapida Fixed jaw body for quick interchangeable jaw plate	Cod. 5.80.6A100	5.80.6A200	5.80.6A300	5.80.6A400	5.80.6A500	5.80.6A600
<b>Art. 807A</b> Corpo ganascia mobile per piastra ganascia intercambiabile rapida Movable jaw body for quick interchangeable jaw plate	Cod. 5.80.7A100	5.80.7A200	5.80.7A300	5.80.7A400	5.80.7A500	5.80.7A600
<b>Art. 808A</b> Corpo ganascia fissa doppia per piastre ganasce intercambiabili rapide Double fixed jaw body for quick interchangeable jaw plate	Cod. 5.80.8A100	5.80.8A200	5.80.8A300	5.80.8A400	5.80.8A500	5.80.8A600
<b>Art. 808B</b> Corpo ganascia fissa doppia ridotta per piastre ganasce intercambiabili rapide Double fixed jaw body narrow for quick interchangeable jaw plate	Cod. 5.80.8B100	5.80.8B200	5.80.8B300	5.80.8B400	5.80.8B500	5.80.8B600

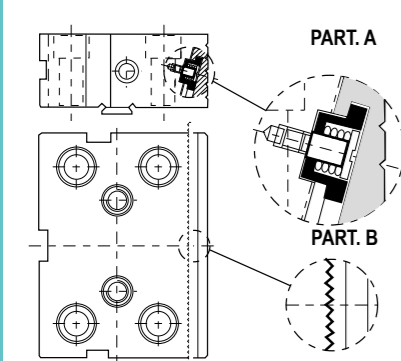

**RAPIDA SOSTITUZIONE DELLE PIASTRE GANASCE DISCENDENTI SENZA BISOGNO DI ALCUN UTENSILE**

Il nuovo sistema con piastre ganasce intercambiabili, conferisce alla morsa FMS un ulteriore aumento di flessibilità dato dalla rapidità di sostituzione delle piastre ganasce e dalla precisione di riposizionamento. La rapidità di sostituzione delle piastre ganasce è resa possibile dal nuovo sistema con perno a molla (PART. A), mentre le righe prismatiche (PART. B) effettuate con mola sagomata sui piani d'appoggio rendono possibile un riposizionamento di elevata precisione. La vasta gamma di piastre ganasce intercambiabili va a soddisfare le più svariate esigenze di lavorazione.

**QUICK HAND CHANGE OF PULL-DOWN JAW PLATES - NO TOOLS NEEDED**

The new system with quick interchangeable jaw plates, increase the FMS vise flexibility, and feature the quick jaw plates replacement and their high precision repositioning. The quickness of the jaw plates replacement is allowed by the new system of pin with spring (PART. A), while the prismatic grooves (PART. B), made with shaped grind wheel on the surface plates, allow a perfect repositioning. The wide range of interchangeable jaws plates can satisfy the most varied workholding needs.

**Art. 806F**  
Piastra ganascia intercambiabile prismatica a pettine  
Prismatic comb interchangeable jaw plate

**Solo 2 per morsa!! Just 2 pcs each vise!!**

Cod.	5.80.6F100	5.80.6F200	5.80.6F300	5.80.6F400	5.80.6F500	5.80.6F600
Piastra ganascia intercambiabile prismatica a pettine Per serraggi autocentranti è necessario ordinare n. 2 piastrelle prismatiche Prismatic comb interchangeable jaw plate For self-centering clamping is necessary to order n. 2 prismatic jaws						
Ø Min / Max	A 6 / 16	9 / 24	13 / 38	15 / 40	15 / 42	15 / 42
	B 4 / 10	7 / 18	9 / 24	9 / 24	9 / 24	9 / 24

**PIASTRE GANASCE INTERCAMBIABILI RAPIDE**  
QUICK INTERCHANGEABLE JAW PLATES

Tipo (grandezza) / Type (size)	1	2	3	4	5	6	
<b>Art. 806B</b> Piastra ganascia lavorabile a pettine Soft comb jaw plate	Cod. 5.80.6B100	5.80.6B200	5.80.6B300	5.80.6B400	5.80.6B500	5.80.6B600	
<b>Art. 806C</b> Piastra ganascia liscia a pettine Smooth comb jaw plate	Cod. 5.80.6C100	5.80.6C200	5.80.6C300	5.80.6C400	5.80.6C500	5.80.6C600	
<b>Art. 806D</b> Piastra ganascia zigrinata a pettine Serrated comb jaw plate	Cod. 5.80.6D100	5.80.6D200	5.80.6D300	5.80.6D400	5.80.6D500	5.80.6D600	
<b>Art. 806E</b> Piastra ganascia a gradino a pettine Step comb jaw plate	Cod. 5.80.6E100	5.80.6E200	5.80.6E300	5.80.6E400	5.80.6E500	5.80.6E600	
<b>KIT RISPARMIO - SAVING KIT</b>							
Piastra ganascia intercambiabile a gradino a pettine (SET di coppie) Step comb interchangeable jaw plate (SET of pair)							
A	Set di 8 pezzi Set of 8 pcs.	3	5	8	13	18	
	Set di 10 pezzi Set of 10 pcs.	3	5	8	13	18	
	Set di 14 pezzi Set of 14 pcs.	3	5	8	13	18	
	Set di 14 pezzi Set of 14 pcs.	3	5	8	13	18	
	Set di 14 pezzi Set of 14 pcs.	3	5	8	13	18	
	Set di 14 pezzi Set of 14 pcs.	3	5	8	13	18	
	Set di 14 pezzi Set of 14 pcs.	3	5	8	13	18	
B	25	30	40	50	60	60	
C	3	3	3	3	3	3	
Cod.	5.80.6E112	5.80.6E212	5.80.6E312	5.80.6E412	5.80.6E512	5.80.6E612	
<b>Art. 806SLD</b> Piastra ganascia scaricata a pettine Discharged comb jaw plate	A 28	38	48	58	63	95	
	B 12	12	12	12	12	12	
	C 14	18	32	42	47	79	
	H 8	8	8	8	8	8	
Cod.	5.80.6SLD1	5.80.6SLD2	5.80.6SLD3	5.80.6SLD4	5.80.6SLD5	5.80.6SLD6	
Cod.	5.80.6SLE1	5.80.6SLE2	5.80.6SLE3	5.80.6SLE4	5.80.6SLE5	5.80.6SLE6	
<b>Art. 806K</b> Piastra ganascia a gradino a pettine con inserti GRIP Comb step jaw plate with GRIP inserts	C 14	18	32	42	47	79	
	H 23	33	43	53	58	73	
Cod.	5.80.6K100	5.80.6K200	5.80.6K300	5.80.6K400	5.80.6K500	5.80.6K600	
<b>Art. 806G</b> Piastra ganascia a pettine con arresto a 90° 90° comb jaw plate	<b>1 per stazione di serraggio !! 1 pc per clamping station !!</b>						
Cod.	5.80.6G100	5.80.6G200	5.80.6G300	5.80.6G400	5.80.6G500	5.80.6G600	
<b>Art. 806H</b> Piastra ganascia bombata a pettine Round comb jaw plate	Cod.	5.80.6H100	5.80.6H200	5.80.6H300	5.80.6H400	5.80.6H500	5.80.6H600
<b>Art. 806M</b> Piastra ganascia a pettine per angolo di 30° o 45° 30° or 45° angle comb jaw plate	<b>1 per stazione di serraggio !! 1 pc per clamping station !!</b>						
Cod.	5.80.6M100	5.80.6M200	5.80.6M300	5.80.6M400	5.80.6M500	5.80.6M600	

Tipo (grandezza) morsa / Vise type (size)	kN	1 25 kN		2 25 kN			3 30 kN		
Apertura massima / Maximum opening	A	2 x 52		2 x 30	2 x 80	2 x 130	2 x 180	2 x 46	2 x 96
	B	25		30			40		
	C	70		90			100		
	D	332	300	400	500	600	400	500	
	E	349	320	420	520	620	425	525	
	G	75		95			125		
	J	63		76			98		
	J1	70		88			111		
	W	74		94			124		
	kg	12	23	30	36	43	46	51	
	Cod.	5.86.61300	5.86.62300	5.86.62400	5.86.62500	5.86.62600	5.86.63400	5.86.63500	

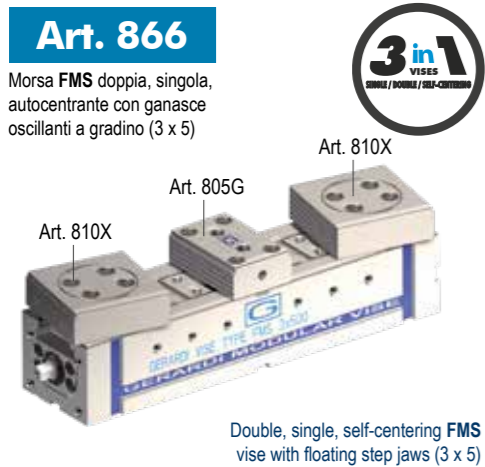

**Art. 866D** (Art. 866 + 802) Morsa + moltiplicatore di coppia / Vise + torque multiplier

Cod.	5.86.6D130	5.86.6D230	5.86.6D240	5.86.6D250	5.86.6D260	5.86.6D340	5.86.6D350
------	------------	------------	------------	------------	------------	------------	------------

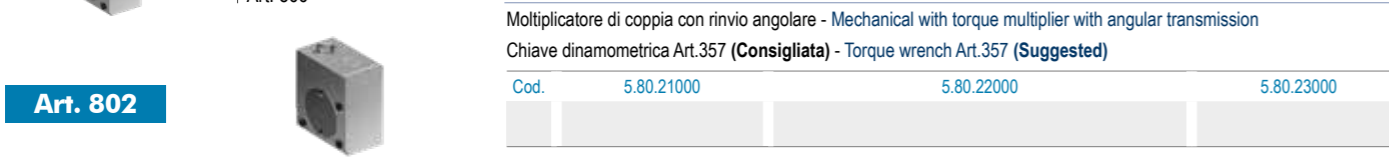

**Art. 866E** (Art. 866 + 890) Morsa + motore idraulico / Vise + hydraulic motor

Cod.	5.86.6E130	5.86.6E230	5.86.6E240	5.86.6E250	5.86.6E260	5.86.6E340	5.86.6E350
------	------------	------------	------------	------------	------------	------------	------------

**Art. 866F** (Art. 866 + 890 + 266B) Morsa + motore idraulico + centralina / Vise + hydraulic motor + power unit

Cod.	5.86.6F130	5.86.6F230	5.86.6F240	5.86.6F250	5.86.6F260	5.86.6F340	5.86.6F350
------	------------	------------	------------	------------	------------	------------	------------

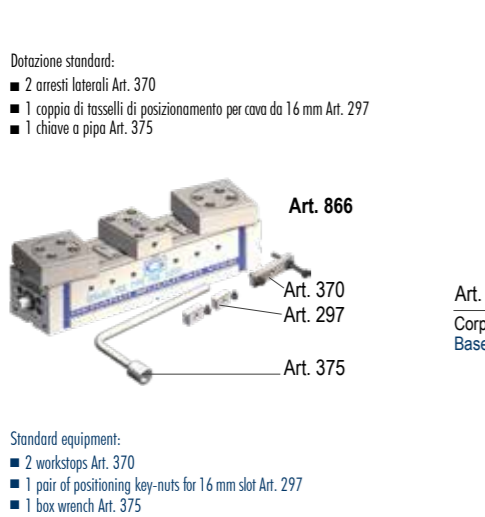

- Dotazione standard:
- 2 arresti laterali Art. 370
  - 1 coppia di tasselli di posizionamento per cava da 16 mm Art. 297
  - 1 chiave a pipa Art. 375
- Standard equipment:
- 2 workstops Art. 370
  - 1 pair of positioning key-nuts for 16 mm slot Art. 297
  - 1 box wrench Art. 375

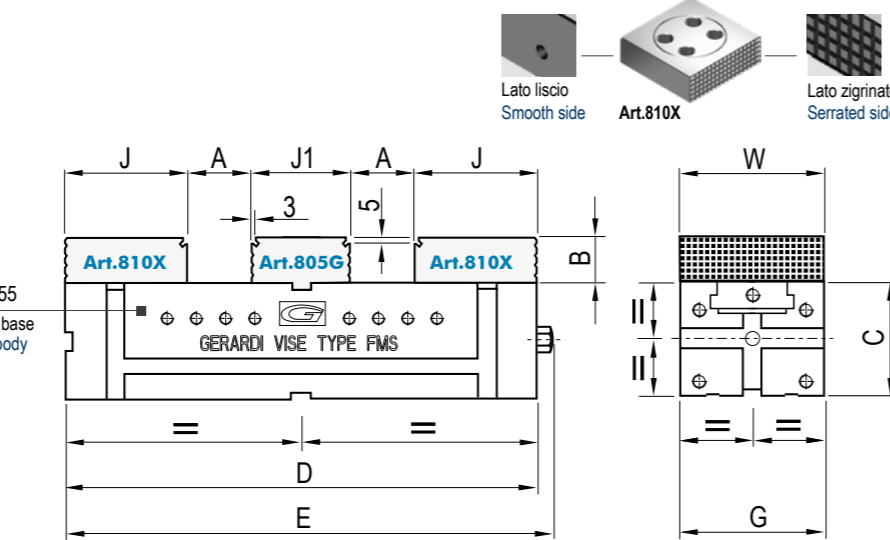

	3 30 kN			4 30 kN				5 32 kN			6 32 kN		
A	2 x 152	2 x 202	2 x 252	2 x 73	2 x 123	2 x 173	2 x 223	2 x 111	2 x 161	2 x 211	2 x 203	2 x 235	2 x 303
B	40			50				60			60		
C	100			120				140			160		
D	600	700	800	500	600	700	800	600	700	800	800	900	1000
E	625	725	825	525	625	725	825	625	725	825	825	925	1025
G	125			145				170			190		
J	106			128				135			143		
J1	84			98				108			108		
W	124			144				169			189		
kg	54	59	64	74	82	91	99	134	144	154	215	235	255
Cod.	5.86.63600	5.86.63700	5.86.63800	5.86.64500	5.86.64600	5.86.64700	5.86.64800	5.86.65600	5.86.65700	5.86.65800	5.86.66800	5.86.66900	5.86.66100

**Art. 866D** (Art. 866 + 802) Morsa + moltiplicatore di coppia / Vise + torque multiplier

Cod.	5.86.6D360	5.86.6D370	5.86.6D380	5.86.6D450	5.86.6D460	5.86.6D470	5.86.6D480	5.86.6D560	5.86.6D570	5.86.6D580	5.86.6D680	5.86.6D690	5.86.6D610
------	------------	------------	------------	------------	------------	------------	------------	------------	------------	------------	------------	------------	------------

**Art. 802** Multiplicatore di coppia con rinvio angolare - Mechanical with torque multiplier with angular transmission

Cod.	5.80.23000	5.80.24000	5.80.25000	5.80.26000
------	------------	------------	------------	------------

**Art. 866E** (Art. 866 + 890) Morsa + motore idraulico / Vise + hydraulic motor

Cod.	5.86.6E360	5.86.6E370	5.86.6E380	5.86.6E450	5.86.6E460	5.86.6E470	5.86.6E480	5.86.6E560	5.86.6E570	5.86.6E580	5.86.6E680	5.86.6E690	5.86.6E610
------	------------	------------	------------	------------	------------	------------	------------	------------	------------	------------	------------	------------	------------

**Art. 866F** (Art. 866 + 890 + 266B) Morsa + motore idraulico + centralina / Vise + hydraulic motor + power unit

Cod.	5.86.6F360	5.86.6F370	5.86.6F380	5.86.6F450	5.86.6F460	5.86.6F470	5.86.6F480	5.86.6F560	5.86.6F570	5.86.6F580	5.86.6F680	5.86.6F690	5.86.6F610
------	------------	------------	------------	------------	------------	------------	------------	------------	------------	------------	------------	------------	------------

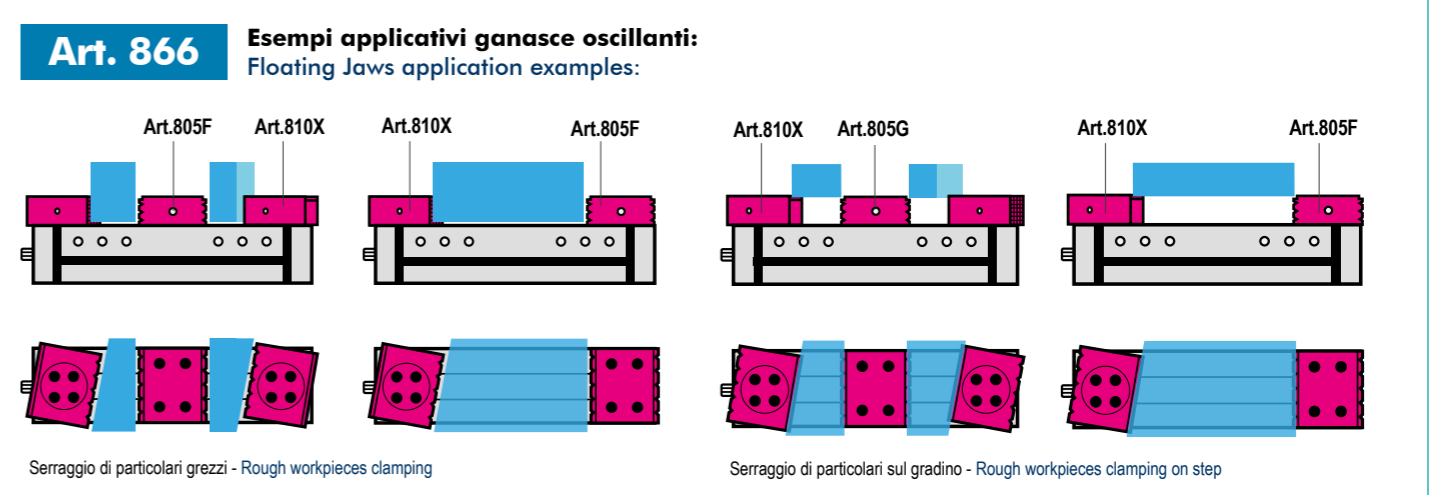

## FUNZIONAMENTO DELLE GANASCE MOBILI OSCILLANTI THE OPERATION OF MOVABLE JAWS

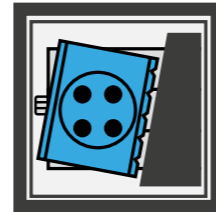

### Art. 810Z

Albero a gradino per ganasce mobili oscillanti  
Step block pin for floating movable jaw

### Art. 810W

Ganascia mobile oscillante zigrinata da un lato, con albero a gradino (Art. 810Z)  
Floating movable jaw one side serrated with step block pin (Art. 810Z)

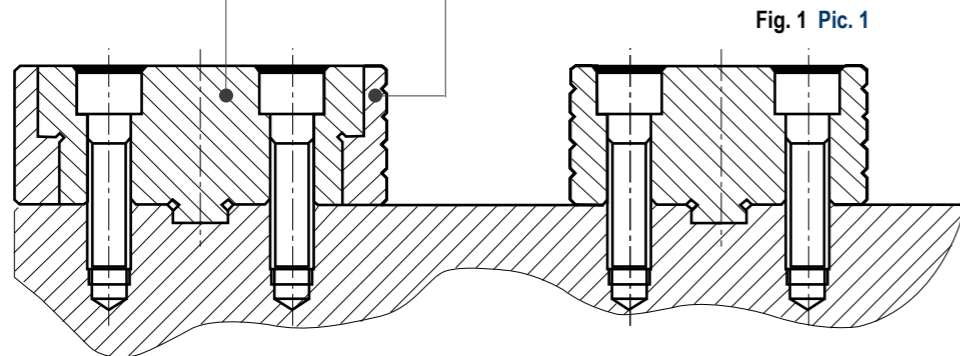

Fig. 1 Pic. 1

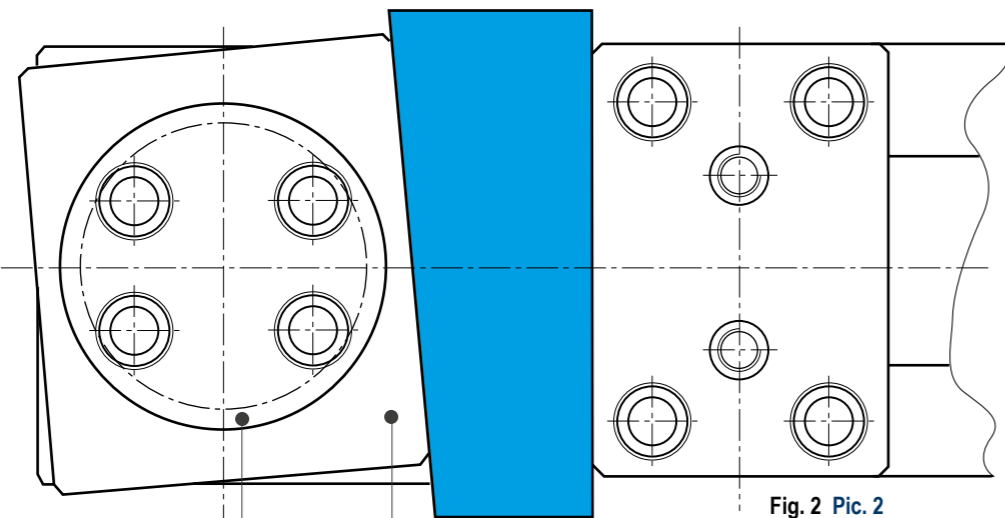

Fig. 2 Pic. 2

### Art. 810Z

Albero a gradino per ganasce mobili oscillanti  
Step block pin for floating movable jaw

### Art. 810W

Ganascia mobile oscillante zigrinata da un lato, con albero a gradino (Art. 810Z)  
Floating movable jaw one side serrated with step block pin (Art. 810Z)

Le ganasce mobili oscillanti consentono il serraggio di pezzi di forma irregolare i cui lati non risultino paralleli (Fig. 2). Questo è reso possibile dall'albero a gradino (Art. 810Z - Fig. 1), posto al centro della ganascia, che pur permettendo la rotazione della ganascia, ne mantiene la precisione ed evita il sollevamento del pezzo mentre viene lavorato. Il tutto a garanzia di un serraggio in piena sicurezza.

Floating movable jaws allow to clamp workpieces with irregular shapes whose sides are not parallels (Pic. 2). In fact thanks to the step block spindle (Art. 810Z - Pic. 1), positioned in the centre of the jaw body, the jaw can float and guarantee at the same time maximum precision and no tilting of the parts while being worked. The safety of the workholding is guaranteed.

## GANASCE MOBILI OSCILLANTI FLOATING MOVABLE JAWS

Tipo (grandezza) / Type (size)	1	2	3	4	5	6
--------------------------------	---	---	---	---	---	---

### Art. 810W\*

Ganascia mobile oscillante zigrinata da un lato con albero a gradino (Art. 810Z)  
Floating movable jaw one side serrated with step block pin (Art. 810Z)

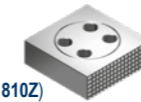

Cod.	5.81.0W100	5.81.0W200	5.81.0W300	5.81.0W400	5.81.0W500	5.81.0W600
------	------------	------------	------------	------------	------------	------------

\* Set viti per fissaggio a richiesta - Set of fixing screws on request

### Art. 810X\*

Ganascia mobile oscillante con gradino 3x5 zigrinata da un lato con albero a gradino (Art. 810Z)  
Floating movable jaw with 3x5 step one side serrated with step block pin (Art. 810Z)

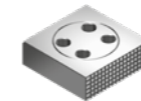

Cod.	5.81.0X100	5.81.0X200	5.81.0X300	5.81.0X400	5.81.0X500	5.81.0X600
------	------------	------------	------------	------------	------------	------------

\* Set viti per fissaggio a richiesta - Set of fixing screws on request

### Art. 810Y\*

Ganascia mobile oscillante con gradino 3x5 con albero a gradino (Art. 810Z)  
Floating movable jaw with 3x5 step with step block pin (Art. 810Z)

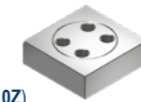

Cod.	5.81.0Y100	5.81.0Y200	5.81.0Y300	5.81.0Y400	5.81.0Y500	5.81.0Y600
------	------------	------------	------------	------------	------------	------------

\* Set viti per fissaggio a richiesta - Set of fixing screws on request

### Art. 810Z

Albero a gradino per ganasce mobili oscillanti  
Step block pin for floating movable jaw



Cod.	5.81.0Z100	5.81.0Z200	5.81.0Z300	5.81.0Z400	5.81.0Z500	5.81.0Z600
------	------------	------------	------------	------------	------------	------------

### Art. 810WA

Corpo ganascia mobile oscillante zigrinata da un lato  
Body floating movable jaw one side serrated

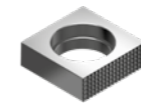

Cod.	5.81.0WA10	5.81.0WA20	5.81.0WA30	5.81.0WA40	5.81.0WA50	5.81.0WA60
------	------------	------------	------------	------------	------------	------------

### Art. 810XA

Corpo ganascia mobile oscillante con gradino 3x5 zigrinata da un lato  
Body floating movable jaw with 3x5 step one side serrated

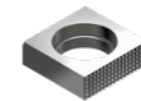

Cod.	5.81.0XA10	5.81.0XA20	5.81.0XA30	5.81.0XA40	5.81.0XA50	5.81.0XA60
------	------------	------------	------------	------------	------------	------------

### Art. 810YA

Corpo ganascia mobile oscillante con gradino 3x5  
Body floating movable jaw with 3x5 step

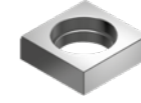

Cod.	5.81.0YA10	5.81.0YA20	5.81.0YA30	5.81.0YA40	5.81.0YA50	5.81.0YA60
------	------------	------------	------------	------------	------------	------------

### Art. 810W

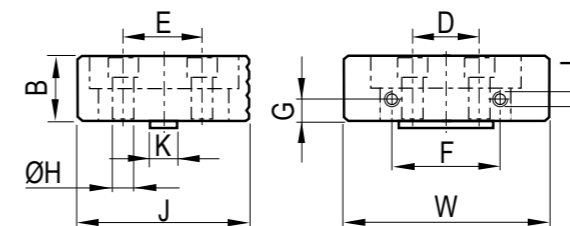

### Art. 810X

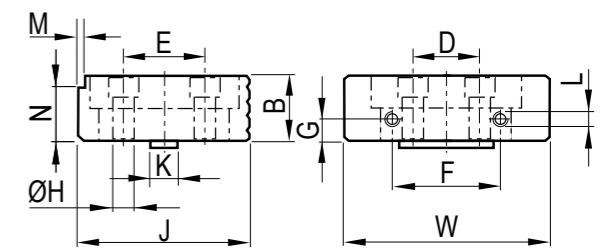

Tipo (grandezza) morsa / Vise (type) size

mm	1	2	3	4	5	6	Tolleranze / Tolerance
B	25	30	40	50	60		- 0,02
D	20	25	38	48	44	54	-
E	32	40	50	60	68	68	-
F	40	50		65		100	-
G		10	15	20		25	-
H	9	11	13		17	22	-
L	M5			M6			-
K				16			H7
M				5			± 0,01
N				3			± 0,02
J	72	84	106	128	135	143	- 0,02
W	74	94	124	144	169	189	-

Tipo (grandezza) morsa / Vise type (size)	1	2				3	
kN	25 kN	25 kN				30 kN	
A1	91	91	141	191	241	141	191
B	20	20				20	
C	70	90				100	
D	332	300	400	500	600	400	500
E	349	320	420	520	620	425	525
G	75	95				125	
J1	50	50				70	
J2	25	25				35	
Ø	30 (H = 16)	30 (H = 16)				30 (H = 16)	
W	100	120				170	
kg	11	20	27	33	40	40	45
Cod.	5.86.71300	5.86.72300	5.86.72400	5.86.72500	5.86.72600	5.86.73400	5.86.73500

**Art. 867**

Morsa FMS doppia, singola, autocentrante con ganasce oscillanti con inserti regolabili

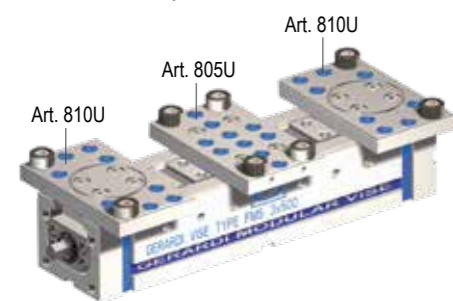

Double, single, self-centering FMS vise with floating jaws with adjustable inserts

**Art. 867D**

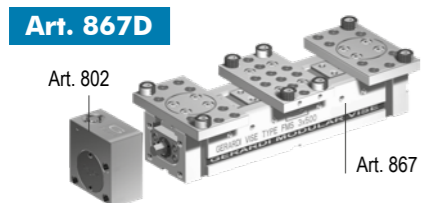

(Art. 867 + 802) Morsa + moltiplicatore di coppia / Vise + torque multiplier

Cod.	5.86.7D130	5.86.7D230	5.86.7D240	5.86.7D250	5.86.7D260	5.86.7D340	5.86.7D350
------	------------	------------	------------	------------	------------	------------	------------

Moltiplicatore di coppia con rinvio angolare - Mechanical with torque multiplier with angular transmission  
Chiave dinamometrica Art.357 (Consigliata) - Torque wrench Art.357 (Suggested)

Cod.	5.80.21000	5.80.22000	5.80.23000
------	------------	------------	------------

**Art. 802**



**Art. 867E**

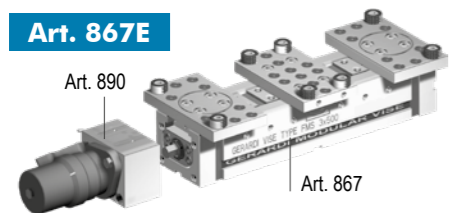

(Art. 867 + 890) Morsa + motore idraulico / Vise + hydraulic motor

Cod.	5.86.7E130	5.86.7E230	5.86.7E240	5.86.7E250	5.86.7E260	5.86.7E340	5.86.7E350
------	------------	------------	------------	------------	------------	------------	------------

**Art. 867F**

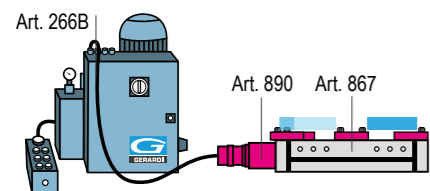

(Art. 867 + 890 + 266B) Morsa + motore idraulico + centralina / Vise + hydraulic motor + power unit

Cod.	5.86.7F130	5.86.7F230	5.86.7F240	5.86.7F250	5.86.7F260	5.86.7F340	5.86.7F350
------	------------	------------	------------	------------	------------	------------	------------

- Dotazione standard:
- 2 arresti laterali Art. 370
  - 1 coppia di tasselli di posizionamento per cava da 16 mm Art. 297
  - 1 chiave a pipa Art. 375

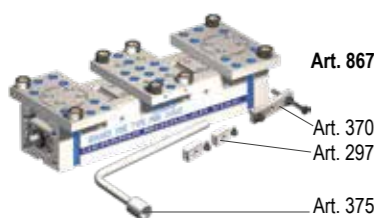

- Standard equipment:
- 2 workstops Art. 370
  - 1 pair of positioning key-nuts for 16 mm slot Art. 297
  - 1 box wrench Art. 375

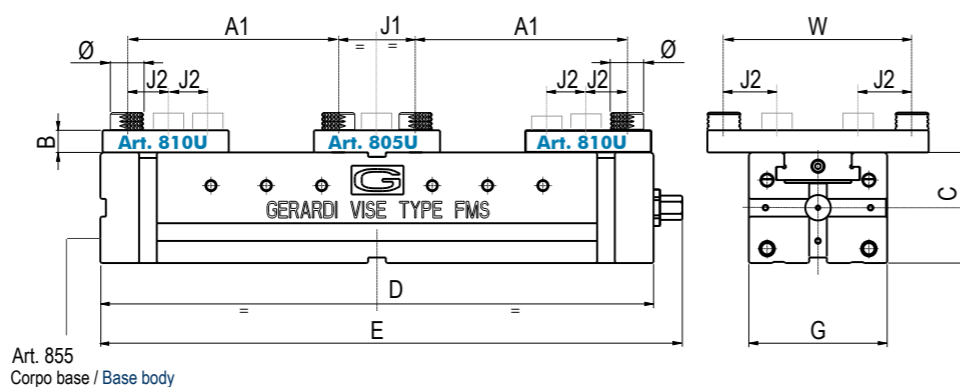

	3			4				5			6		
	30 kN			30 kN				32 kN			32 kN		
A1	241	291	341	191	241	291	341	231	281	331	331	381	431
B	20	30				35			35				
C	100	120				140			160				
D	600	700	800	500	600	700	800	600	700	800	800	900	1000
E	625	725	825	525	625	725	825	625	725	825	825	925	1025
G	125	145				170			190				
J1	70	80				100			100				
J2	35	40				40			40				
Ø	30 (H = 16)	30 (H = 16)				40 (H = 30)			40 (H = 30)				
W	170	220				250			300				
kg	50	55	60	68	76	85	93	124	134	144	200	220	240
Cod.	5.86.73600	5.86.73700	5.86.73800	5.86.74500	5.86.74600	5.86.74700	5.86.74800	5.86.75600	5.86.75700	5.86.75800	5.86.76800	5.86.76900	5.86.76100

**Art. 867D**

(Art. 867 + 802) Morsa + moltiplicatore di coppia / Vise + torque multiplier

Cod.	5.86.7D360	5.86.7D370	5.86.7D380	5.86.7D450	5.86.7D460	5.86.7D470	5.86.7D480	5.86.7D560	5.86.7D570	5.86.7D580	5.86.7D680	5.86.7D690	5.86.7D610
------	------------	------------	------------	------------	------------	------------	------------	------------	------------	------------	------------	------------	------------

**Art. 802**

Moltiplicatore di coppia con rinvio angolare - Mechanical with torque multiplier with angular transmission

Cod.	5.80.23000	5.80.24000	5.80.25000	5.80.26000
------	------------	------------	------------	------------

**Art. 867E**

(Art. 867 + 890) Morsa + motore idraulico / Vise + hydraulic motor

Cod.	5.86.7E360	5.86.7E370	5.86.7E380	5.86.7E450	5.86.7E460	5.86.7E470	5.86.7E480	5.86.7E560	5.86.7E570	5.86.7E580	5.86.7E680	5.86.7E690	5.86.7E610
------	------------	------------	------------	------------	------------	------------	------------	------------	------------	------------	------------	------------	------------

**Art. 867F**

(Art. 867 + 890 + 266B) Morsa + motore idraulico + centralina / Vise + hydraulic motor + power unit

Cod.	5.86.7F360	5.86.7F370	5.86.7F380	5.86.7F450	5.86.7F460	5.86.7F470	5.86.7F480	5.86.7F560	5.86.7F570	5.86.7F580	5.86.7F680	5.86.7F690	5.86.7F610
------	------------	------------	------------	------------	------------	------------	------------	------------	------------	------------	------------	------------	------------

**Art. 867**

**Esempi applicativi ganasce oscillanti regolabili:**  
Floating adjustable jaws application examples:

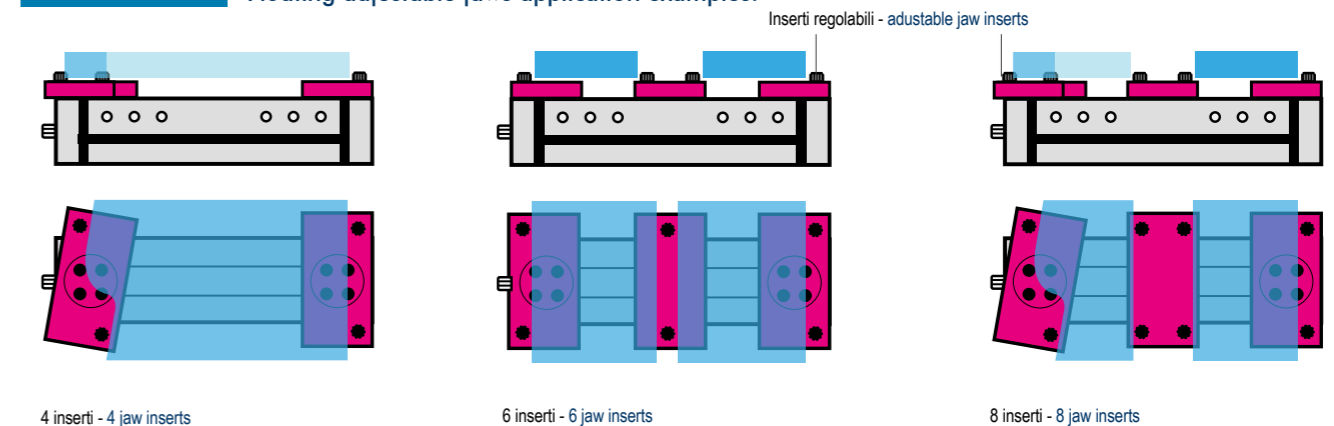

4 inserti - 4 jaw inserts

6 inserti - 6 jaw inserts

8 inserti - 8 jaw inserts

## FUNZIONAMENTO DELLE GANASCE MOBILI OSCILLANTI CON INSERTI

### HOW TO OPERATE FLOATING MOVABLE JAWS WITH INSERTS

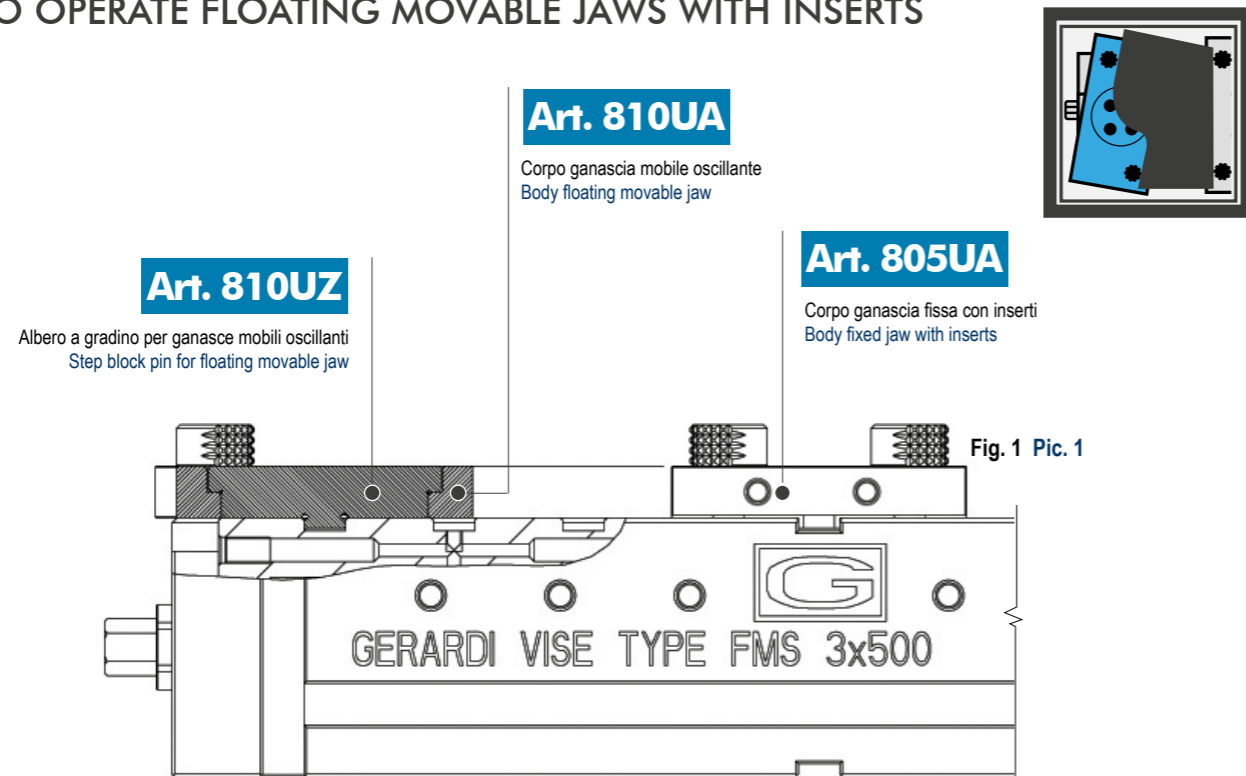

#### Art. 812

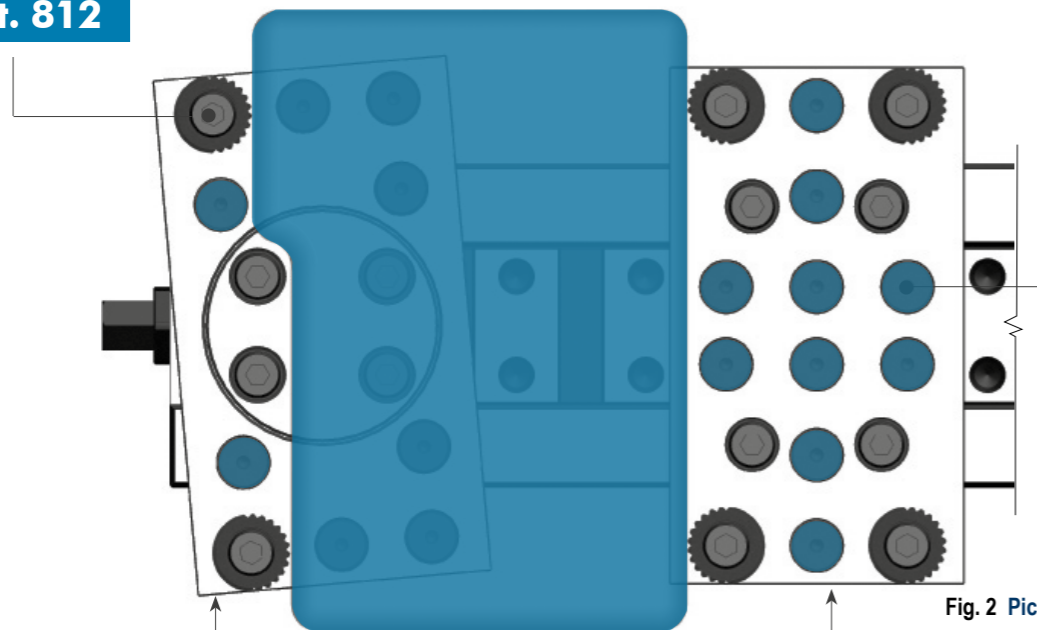

#### Art. 84U

Tappo in alluminio (EXTRA)  
Aluminum cap (ETRA)

#### Art. 810U

Ganascia mobile oscillante con inserti  
Floating movable jaw with inserts

#### Art. 805U

Ganascia fissa con inserti  
Fixed jaw with inserts

Le ganasce mobili oscillanti consentono il serraggio di pezzi di forma irregolare i cui lati non risultino paralleli (Fig. 2). Questo è reso possibile dall'albero a gradino (Art. 810UZ - Fig. 1), posto al centro della ganascia, che pur permettendo la rotazione della ganascia, ne mantiene la precisione ed evita il sollevamento del pezzo mentre viene lavorato. Il tutto a garanzia di un serraggio in piena sicurezza. Gli inserti estremizzano ulteriormente la versatilità delle ganasce mobili oscillanti della morsa FMS.

Floating movable jaws allow to clamp workpieces with irregular shapes whose sides are not parallels (Pic. 2). In fact thanks to the step block spindle (Art. 810UZ - Pic. 1), positioned in the centre of the jaw body, the jaw can float and guarantee at the same time maximum precision and no tilting of the parts while being worked. The safety of the workholding is guaranteed. The insert further increase the versatility of the FMS floating movable jaws.

## GANASCE FISSE & MOBILI FMS

### FMS FIXED AND MOVABLE JAWS

Tipo (grandezza) / Type (size)	1	2	3	4	5	6
<b>Art. 810U*</b> Ganascia mobile regolabile oscillante con inserti Floating movable jaw with inserts	Cod. 5.81.0U100	5.81.0U200	5.81.0U300	5.81.0U400	5.81.0U500	5.81.0U600
* Set viti per fissaggio a richiesta - Set of fixing screws on request						
<b>Art. 810UA</b> Corpo ganascia mobile oscillante Body floating movable jaw	Cod. 5.81.0UA10	5.81.0UA20	5.81.0UA30	5.81.0UA40	5.81.0UA50	5.81.0UA60
<b>Art. 810UZ*</b> Albero a gradino per ganasce mobili oscillanti Step block pin for floating movable jaw	Cod. 5.81.0UZ10	5.81.0UZ20	5.81.0UZ30	5.81.0UZ40	5.81.0UZ50	5.81.0UZ60
* Set viti per fissaggio a richiesta - Set of fixing screws on request						
<b>Art. 810Q*</b> Ganascia mobile regolabile con inserti Movable jaw with inserts	Cod. 5.81.0Q100	5.81.0Q200	5.81.0Q300	5.81.0Q400	5.81.0Q500	5.81.0Q600
* Set viti per fissaggio a richiesta - Set of fixing screws on request						
<b>Art. 810QA</b> Corpo ganascia regolabile mobile per inserti Body movable jaw for inserts	Cod. 5.81.0QA10	5.81.0QA20	5.81.0QA30	5.81.0QA40	5.81.0QA50	5.81.0QA60
<b>Art. 805U*</b> Ganascia fissa regolabile con inserti Fixed jaw with inserts	Cod. 5.80.5U100	5.80.5U200	5.80.5U300	5.80.5U400	5.80.5U500	5.80.5U600
* Set viti per fissaggio a richiesta - Set of fixing screws on request						
<b>Art. 805UA</b> Corpo ganascia fissa regolabile per inserti Body fixed jaw per inserti	Cod. 5.80.5UA10	5.80.5UA20	5.80.5UA30	5.80.5UA40	5.80.5UA50	5.80.5UA60
<b>Art. 812</b> Inserto liscio e zigrinato Smooth and serrated insert	Ø 30		Ø 40			
	H 16		H 30			
<b>Art. 812A</b> Inserto liscio Smooth insert	Cod. 5.81.21000		5.81.25000			
	Cod. 5.81.2A100		5.81.2A500			
	Cod. 5.81.2C100		5.81.2C500			
<b>Art. 812C</b> Inserto zigrinato Serrated insert						
<b>Art. 813</b> Inserto liscio e zigrinato alto Smooth and serrated high insert	Ø 30		Ø 40			
	H 28		H 50			
<b>Art. 813A</b> Inserto liscio alto Smooth high insert	Cod. 5.81.31000		5.81.35000			
	Cod. 5.81.3A100		5.81.3A500			
	Cod. 5.81.3C100		5.81.3C500			
<b>Art. 813C</b> Inserto zigrinato alto Serrated high insert						
<b>Art. 815</b> Inserto liscio e zigrinato a gradino Pair of smooth and serrated step insert	H 16		H 30			
<b>Art. 815A</b> Inserto liscio a gradino Smooth step insert	Cod. 5.81.51000		5.81.55000			
	Cod. 5.81.5A100		5.81.5A500			
	Cod. 5.81.5C100		5.81.5C500			
<b>Art. 815C</b> Inserto zigrinato a gradino Serrated step insert						
<b>Art. 812B</b> Inserto in acciaio lavorabile Insert in machineable steel metal	Ø 40		Ø 60			
	H 40		H 60			
	Cod. 5.81.2B100		5.81.2B500			
<b>Art. 84U</b> Tappo in alluminio (EXTRA) Aluminum cap (ETRA)	Cod. 5.84.U1000		5.84.U5000			



Tipo (grandezza) morsa / Vise type (size)	1		2				3	
	25 kN		25 kN				30 kN	
A	130	230	182	282	382	482	244	344
B	99,5		117				137	
C	70		90				100	
D	232	332	300	400	500	600	400	500
E	249	349	320	420	520	620	425	525
F	169,5		207				237	
G	75		95				125	
H	75		85				98	
L	56		64				84	
J3	76	76	101				132	
J4	55	55	63				82	
X	39,5		47				57	
W	74		94				124	
kg	-		-				-	

Cod. 5.86.81200 5.86.81300 5.86.82300 5.86.82400 5.86.82500 5.86.82600 5.86.83400 5.86.83500

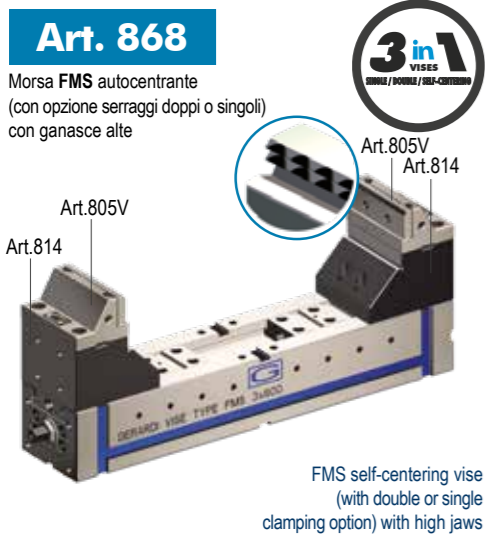

**Art. 868D** (Art. 868 + 802) Morsa + moltiplicatore di coppia / Vise + torque multiplier

Cod.	5.86.8D120	5.86.8D130	5.86.8D230	5.86.8D240	5.86.8D250	5.86.8D260	5.86.8D340	5.86.8D350
------	------------	------------	------------	------------	------------	------------	------------	------------

**Art. 802** Moltiplicatore di coppia con rinvio angolare - Mechanical with torque multiplier with angular transmission

Chiave dinamometrica Art.357 (Consigliata) - Torque wrench Art.357 (Suggested)

Cod.	5.80.21000	5.80.22000	5.80.23000
------	------------	------------	------------

**Art. 868E** (Art. 868 + 890) Morsa + motore idraulico / Vise + hydraulic motor

Cod.	5.86.8E120	5.86.8E130	5.86.8E230	5.86.8E240	5.86.8E250	5.86.8E260	5.86.8E340	5.86.8E350
------	------------	------------	------------	------------	------------	------------	------------	------------

**Art. 868F** (Art. 868 + 890 + 266B) Morsa + motore idraulico + centralina / Vise + hydraulic motor + power unit

Cod.	5.86.8F120	5.86.8F130	5.86.8F230	5.86.8F240	5.86.8F250	5.86.8F260	5.86.8F340	5.86.8F350
------	------------	------------	------------	------------	------------	------------	------------	------------

- Dotazione standard:**
- 2 arresti laterali Art. 370
  - 1 coppia di tasselli di posizionamento per cava da 16 mm Art. 297
  - 1 chiave a pipa Art. 375
- Standard equipment:**
- 2 workstops Art. 370
  - 1 pair of positioning key-nuts for 16 mm slot Art. 297
  - 1 box wrench Art. 375

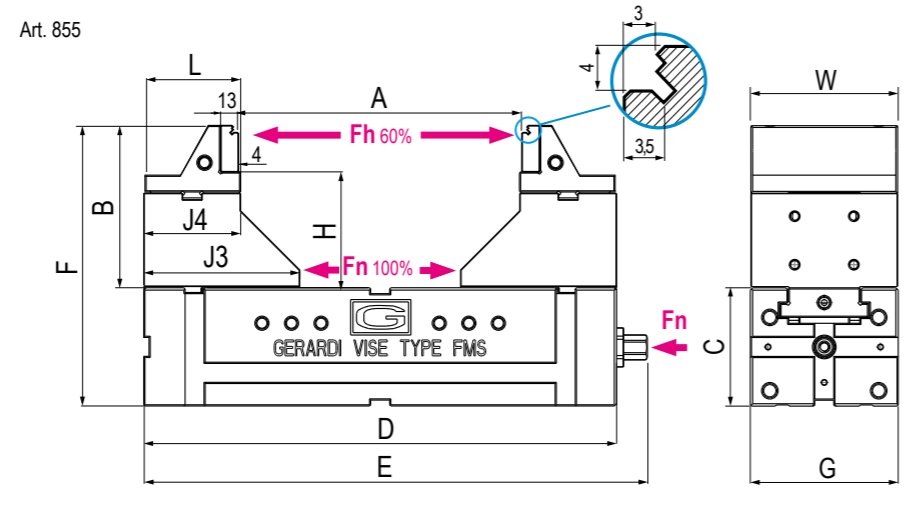

	3			4				5			6		
	30 kN			30 kN				32 kN			32 kN		
A	444	544	644	316	416	516	616	396	496	596	596	696	796
B	137			171				186			246		
C	100			120				140			160		
D	600	700	800	500	600	700	800	600	700	800	800	900	1000
E	625	725	825	525	625	725	825	625	725	825	825	925	1025
F	237			291				326			406		
G	125			145				170			190		
H	98			128				138			180		
L	84			97				107			107		
J3	132			154				169			189		
J4	82			96				106			106		
X	57			64				66			86		
W	124			144				169			189		
kg	-			-				-			-		

Cod. 5.86.83600 5.86.83700 5.86.83800 5.86.84500 5.86.84600 5.86.84700 5.86.84800 5.86.85600 5.86.85700 5.86.85800 5.86.86800 5.86.86900 5.86.86100

**Art. 868D** (Art. 868 + 802) Morsa + moltiplicatore di coppia / Vise + torque multiplier

Cod.	5.86.8D360	5.86.8D370	5.86.8D380	5.86.8D450	5.86.8D460	5.86.8D470	5.86.8D480	5.86.8D560	5.86.8D570	5.86.8D580	5.86.8D680	5.86.8D690	5.86.8D610
------	------------	------------	------------	------------	------------	------------	------------	------------	------------	------------	------------	------------	------------

**Art. 802** Moltiplicatore di coppia con rinvio angolare - Mechanical with torque multiplier with angular transmission

Cod.	5.80.23000	5.80.24000	5.80.25000	5.80.26000
------	------------	------------	------------	------------

**Art. 868E** (Art. 868 + 890) Morsa + motore idraulico / Vise + hydraulic motor

Cod.	5.86.8E360	5.86.8E370	5.86.8E380	5.86.8E450	5.86.8E460	5.86.8E470	5.86.8E480	5.86.8E560	5.86.8E570	5.86.8E580	5.86.8E680	5.86.8E690	5.86.8E610
------	------------	------------	------------	------------	------------	------------	------------	------------	------------	------------	------------	------------	------------

**Art. 868F** (Art. 868 + 890 + 266B) Morsa + motore idraulico + centralina / Vise + hydraulic motor + power unit

Cod.	5.86.8F360	5.86.8F370	5.86.8F380	5.86.8F450	5.86.8F460	5.86.8F470	5.86.8F480	5.86.8F560	5.86.8F570	5.86.8F580	5.86.8F680	5.86.8F690	5.86.8F610
------	------------	------------	------------	------------	------------	------------	------------	------------	------------	------------	------------	------------	------------

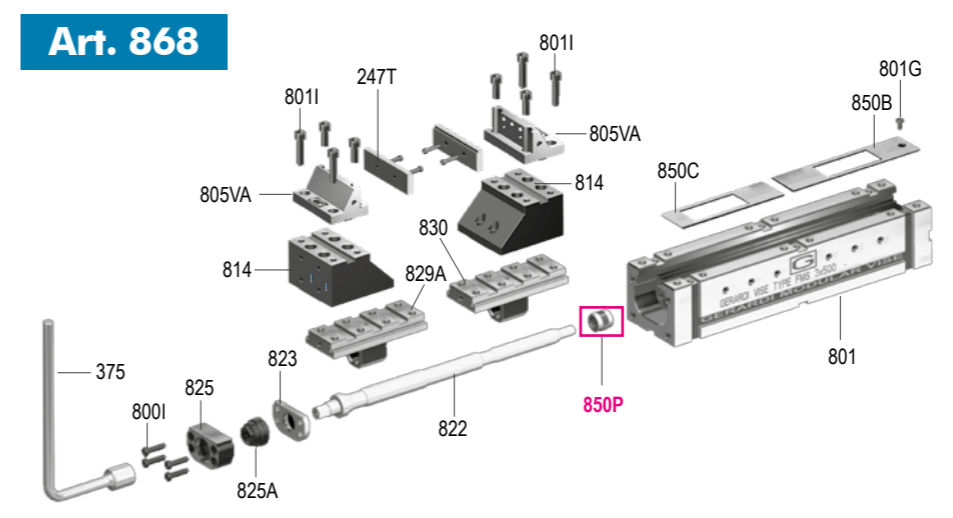

Art.	Pag.	Art.	Pag.
375	4.35	830	5.52
800I	5.61	850B	5.61
801	5.50	850C	5.61
801G	5.61	850P	5.72
801I	5.61	814	5.56
810J	5.56	805VA	5.35
822	5.53	247T	5.35
823	5.59	-	-
825	5.59	-	-
825A	5.61	-	-
829A	5.52	-	-

## POSSIBILI COMBINAZIONI DELLA MORSA Art.868 POSSIBLE ARRANGEMENTS OF THE Art.868 VISE

Orientamento base mobile Art.814 per massima apertura ganasce  
Movable base Art.814 oriented for the maximum jaws opening

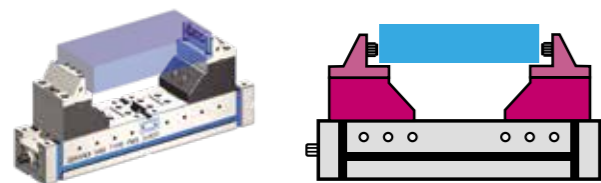
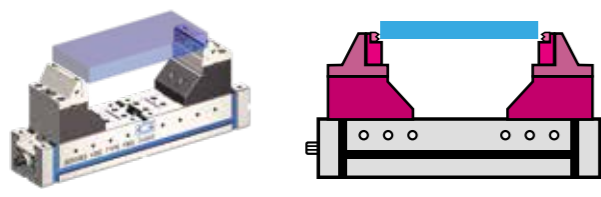
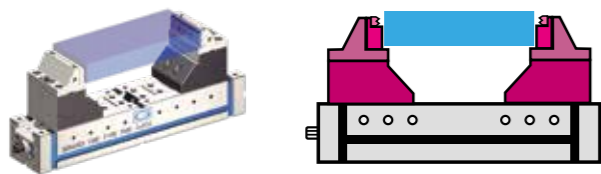

Orientamento base mobile Art.814 per chiusura ganasce a zero  
Movable base Art.814 oriented in order to close jaws completely

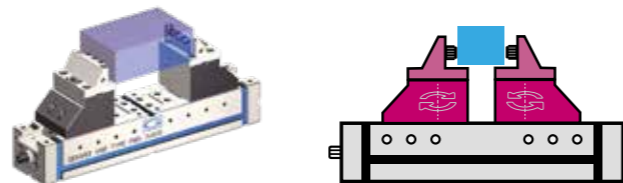
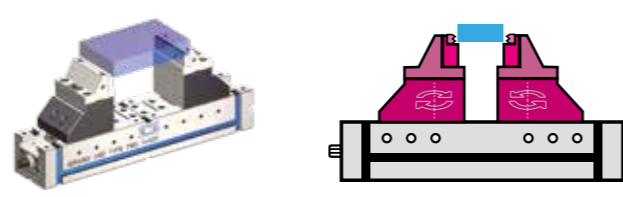
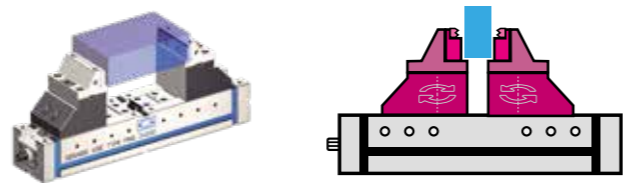

### Art. 868

**1** Art.90  
**PUNTALE TEMPRATO GRIP**  
HARDENED GRIP POINT

**2** Art.247T  
**PIASTRINA PIANA GRIP**  
STRAIGHT JAW PLATE GRIP

**3** Art.805VA  
**CORPO GANASCIA**  
JAW PLATE BODY

**4** Art.814  
**BASE PER GANASCE FISSE**  
BASE FOR FIXED JAWS

**5** Art.855  
**CORPO BASE CUBO**  
CUBE BASE BODY

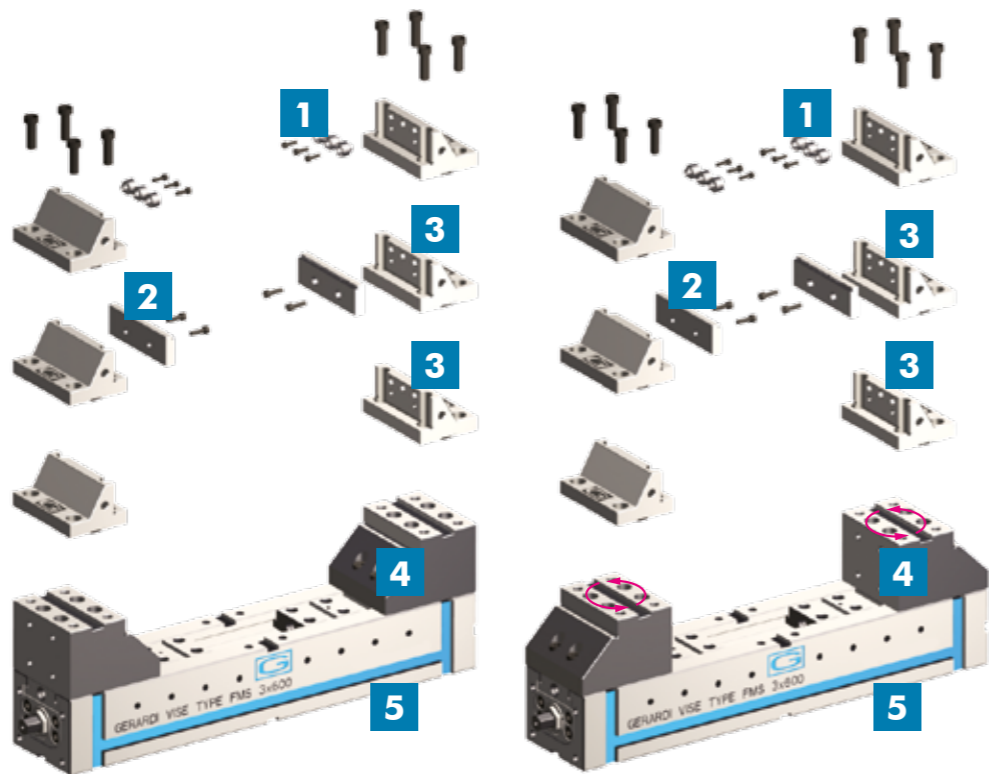

Possibilità di utilizzo di qualsiasi ganascia fissa FMS anziché del corpo ganascia 805V. Possibilità di due posizioni per ciascuna ganascia fissa e per base ganascia mobile Art.814  
Possibility to use each FMS fixed jaw instead of jaw body Art.805V. Possibility of two positions (at 180°) for each fixed jaw and for movable base jaw Art.814

## GANASCE & PIASTRE GANASCE PER Art.868 JAWS & JAW PLATES FOR Art.868

Tipo (grandezza) / Type (size)

1 2 3 4 5 6

### Art. 805V\*

Ganascia per piastrine e puntali  
Jaw for plates and points



Cod. 5.80.5V100 5.80.5V200 5.80.5V300 5.80.5V400 5.80.5V500 5.80.5V600

\* Viti per fissaggio a richiesta Fixing screws on request

### Art. 90

Puntale temprato GRIP  
Hardened GRIP Insert



Cod. 5.90.10000

### Art. 247T (W2)

Piastra piana temprata GRIP  
con larghezza ridotta  
Hardened straight jaw plate GRIP  
with narrow width

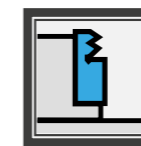

Cod. 4.24.7T100 4.24.7T200 4.24.7T300 4.24.7T400 4.24.7T500 4.24.7T600

Per qualsiasi piastra piana speciale, raddoppiare il prezzo  
For special Taylor made straight jaw plate double the price

PIASTRE GANASCE "GRIP" JAW PLATES

**MINOR SUPERFICIE DI CONTATTO + PRESSIONE DI SERRAGGIO**  
**LESS SURFACE CONTACT + CLAMPING PRESSURE**

### Art. 805VA

Corpo Ganascia  
Jaw for plates and points

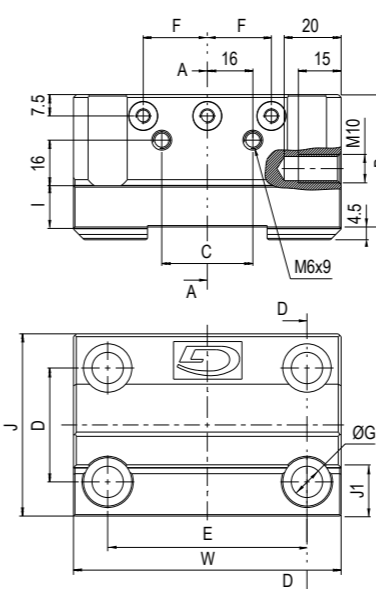

### Art. 247T

Piastrina piana temprata GRIP  
Hardened straight jaw plate GRIP

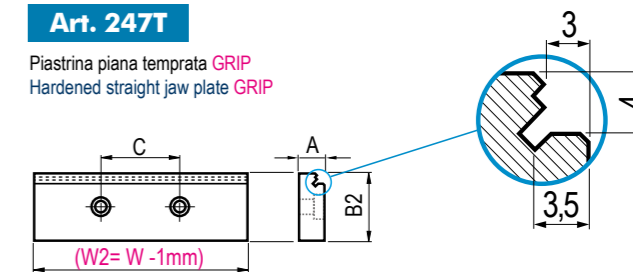

### Art. 90

Puntale temprato GRIP  
Hardened GRIP Point

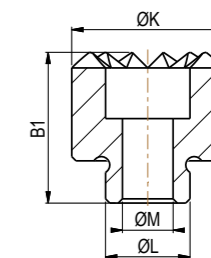

mm	1	2	3	4	5	6
W	74	94	124	144	169	189
A	12	12	13	13	18	18
B	39,5	47	57	61	66	86
B2	24,5	32	39	43	48	56
C	25	32	50	50	76	90
D	32	40	50	60	68	68
E	56	70	92	108	126	144
F	2X26	3x20	3x25	4x20	4x25	4x30
ØG	9	11	13	17	17	21
I	15	15	18	18	18	20
J	56	64	84	97	107	107
J1				17		
ØK	-			18		-
ØL	-			10 h8		-
ØM	-			6		-

Tipo (grandezza) morsa / Vise type (size)	kN	1 25 kN		2 25 kN				3 30 kN	
Apertura minima - massima / minimum - maximum Aperture	A	10 / 25	10 / 25	20 / 50	20 / 50	20 / 50	20 / 50	40 / 100	40 / 100
Apertura minima - massima / minimum - maximum Aperture	A1	10 / 15	10 / 15	10 / 25	10 / 25	10 / 25	10 / 25	25 / 50	25 / 50
	B	34		55				90	
	C	70		90				100	
	D	232	332	300	400	500	600	400	500
	E	249	349	320	420	520	620	425	525
	F	104		145				190	
	G	75		95				125	
	J	48	60	102				132	
	W	50		75				100	
	kg	9	12	23	30	63	43	47	52
Cod.		5.87.01200	5.87.01300	5.87.02300	5.87.02400	5.87.02500	5.87.02600	5.87.03400	5.87.03500

**Art. 870**

Morsa FMS autocentrante (opzione doppia o singola) con ganasce prismatiche

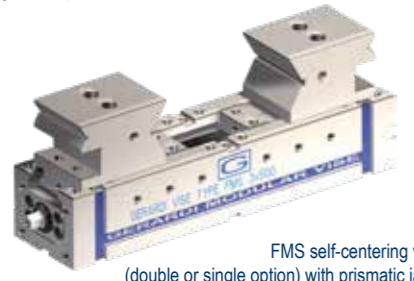

FMS self-centering vise (double or single option) with prismatic jaws

**Art. 870D**

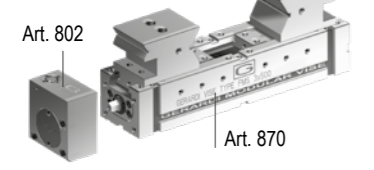

(Art. 870 + 802) Morsa + moltiplicatore di coppia / Vise + torque multiplier

Cod.	5.87.0D120	5.87.0D130	5.87.0D230	5.87.0D240	5.87.0D250	5.87.0D260	5.87.0D340	5.87.0D350
------	------------	------------	------------	------------	------------	------------	------------	------------

Moltiplicatore di coppia con rinvio angolare - Mechanical with torque multiplier with angular transmission  
Chiave dinamometrica Art.357 (Consigliata) - Torque wrench Art.357 (Suggested)

**Art. 802**



Cod.	5.80.21000	5.80.22000	5.80.23000
------	------------	------------	------------

**Art. 870E**

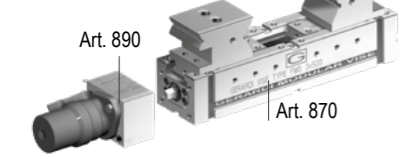

(Art. 870 + 890) Morsa + motore idraulico / Vise + hydraulic motor

Cod.	5.87.0E120	5.87.0E130	5.87.0E230	5.87.0E240	5.87.0E250	5.87.0E260	5.87.0E340	5.87.0E350
------	------------	------------	------------	------------	------------	------------	------------	------------

**Art. 870F**

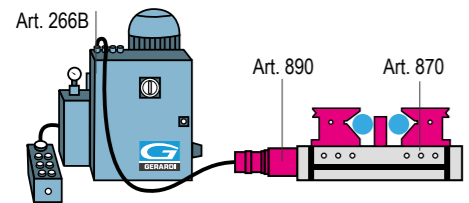

(Art. 870 + 890 + 266B) Morsa + motore idraulico + centralina / Vise + hydraulic motor + power unit

Cod.	5.87.0F120	5.87.0F130	5.87.0F230	5.87.0F240	5.87.0F250	5.87.0F260	5.87.0F340	5.87.0F350
------	------------	------------	------------	------------	------------	------------	------------	------------

- Dotazione standard:
- 2 arresti laterali Art. 370
  - 1 coppia di tasselli di posizionamento per cava da 16 mm Art. 297
  - 1 chiave a pipa Art. 375

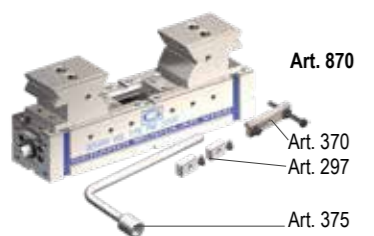

- Standard equipment:
- 2 workstops Art. 370
  - 1 pair of positioning key-nuts for 16 mm slot Art. 297
  - 1 box wrench Art. 375

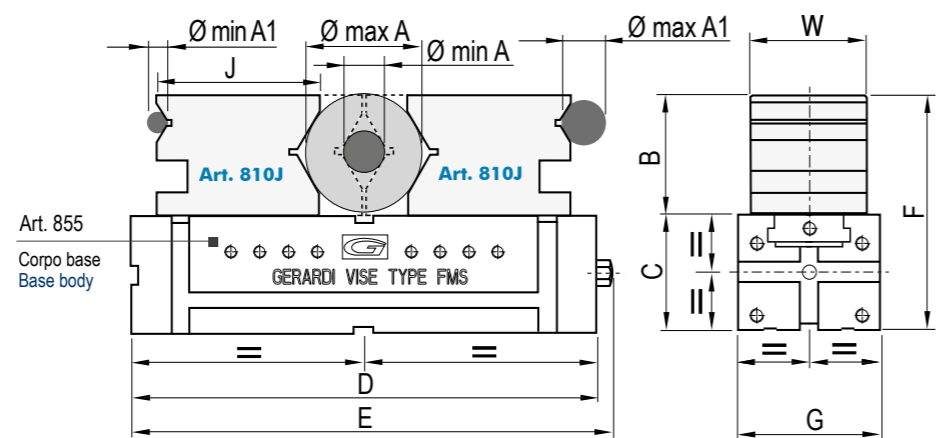

	3 30 kN			4 30 kN				5 32 kN			6 32 kN		
A	40 / 100	40 / 100	40 / 100	40 / 150	40 / 150	40 / 150	40 / 150	63 / 200	65 / 240	80 / 280	100 / 300	120 / 350	140 / 400
A1	25 / 50	25 / 50	25 / 50	30 / 60	30 / 60	30 / 60	30 / 60	35 / 70	35 / 70	35 / 80	40 / 140	40 / 140	40 / 140
B	90			132				171	191	226	250	275	300
C	100			120				140				160	
D	600	700	800	500	600	700	800	600	700	800	800	900	1000
E	625	725	825	525	625	725	825	625	725	825	825	925	1025
F	190			252				311	331	366	410	435	460
G	125			145				170				190	
J	132			156				176				174	
W	100			132				140				160	
kg	57	62	67	74	82	91	99	135	145	155	225	245	265
Cod.	5.87.03600	5.87.03700	5.87.03800	5.87.04500	5.87.04600	5.87.04700	5.87.04800	5.87.05600	5.87.05700	5.87.05800	5.87.06800	5.87.06900	5.87.06100

**Art. 870D**

(Art. 870 + 802) Morsa + moltiplicatore di coppia / Vise + torque multiplier

Cod.	5.87.0D360	5.87.0D370	5.87.0D380	5.87.0D450	5.87.0D460	5.87.0D470	5.87.0D480	5.87.0D560	5.87.0D570	5.87.0D580	5.87.0D680	5.87.0D690	5.87.0D610
------	------------	------------	------------	------------	------------	------------	------------	------------	------------	------------	------------	------------	------------

**Art. 802**

Moltiplicatore di coppia con rinvio angolare - Mechanical with torque multiplier with angular transmission

Cod.	5.80.23000	5.80.24000	5.80.25000	5.80.26000
------	------------	------------	------------	------------

**Art. 870E**

(Art. 870 + 890) Morsa + motore idraulico / Vise + hydraulic motor

Cod.	5.87.0E360	5.87.0E370	5.87.0E380	5.87.0E450	5.87.0E460	5.87.0E470	5.87.0E480	5.87.0E560	5.87.0E570	5.87.0E580	5.87.0E680	5.87.0E690	5.87.0E610
------	------------	------------	------------	------------	------------	------------	------------	------------	------------	------------	------------	------------	------------

**Art. 870F**

(Art. 870 + 890 + 266B) Morsa + motore idraulico + centralina / Vise + hydraulic motor + power unit

Cod.	5.87.0F360	5.87.0F370	5.87.0F380	5.87.0F450	5.87.0F460	5.87.0F470	5.87.0F480	5.87.0F560	5.87.0F570	5.87.0F580	5.87.0F680	5.87.0F690	5.87.0F610
------	------------	------------	------------	------------	------------	------------	------------	------------	------------	------------	------------	------------	------------

**Art. 870**

Esempi applicativi ganasce prismatiche: Prismatic jaws application examples:

Ganasce ruotate di 180° - Jaws rotated 180°



**Art. 870A**

Pag.5.54 Page. 5.54

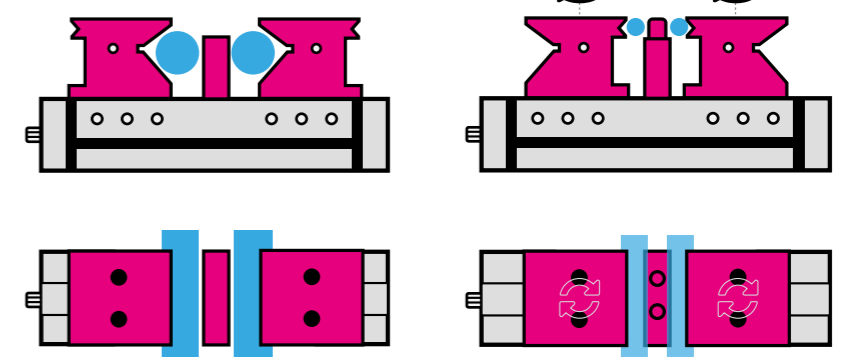

Per il serraggio di 2 particolari tondi contemporaneamente per mezzo della ganasca intermedia alta Art.870A  
For clamping 2 round workpieces simultaneously by intermediate high jaw Art.870A

**N.B.:** Realizzabili versioni speciali per diametro Max.1500 - Special Types available on request for up to Ø1500

Tipo (grandezza) morsa / Vise type (size)	kN	1 25 kN		2 25 kN			3 30 kN		
Apertura massima / Maximum opening	A	85	185	170	270	370	470	230	330
Minima apertura interno-esterno / Minimum opening inside-outside	A1	115 / 200	115 / 300	130 / 300	130 / 400	130 / 500	130 / 600	170 / 400	170 / 500
<b>Art. 800</b> Morsa a Serraggio Meccanico solo per serraggi singoli	B	25		30			40		
<b>SPECIFICA SOLO PER SERRAGGI SINGOLI</b> SPECIFIC FOR SINGLE CLAMPING ONLY	C	70		90			100		
	D	232	332	300	400	500	600	400	500
	E	249	349	320	420	520	620	425	525
	G	75		95			125		
	W	74		94			124		
	kg	7	10	18	25	32	39	40	45
	Cod.	5.80.01200	5.80.01300	5.80.02300	5.80.02400	5.80.02500	5.80.02600	5.80.03400	5.80.03500
<b>Art. 800Z</b> Corpo morsa Vise body	Cod.	5.80.0Z120	5.80.0Z130	5.80.0Z230	5.80.0Z240	5.80.0Z250	5.80.0Z260	5.80.0Z340	5.80.0Z350

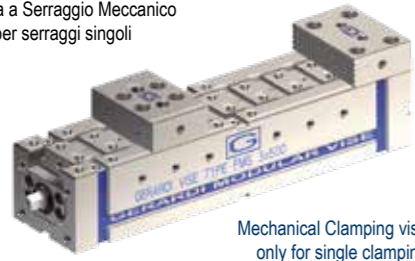

Mechanical Clamping vise only for single clamping

**Art. 800A** Meccanica con predisposizione idraulica solo per serraggi singoli / Mechanical with prepared hydraulic connection only for single clamping

E1	273	373	370,5	470,5	570,5	670,5	485	585
Cod.	5.80.0A120	5.80.0A130	5.80.0A230	5.80.0A240	5.80.0A250	5.80.0A260	5.80.0A340	5.80.0A350



Connettore Idraulico - Hydraulic Connexion

**Art. 882A**

Corsa - Stroke	mm	4	7	10
Superficie - Surface	cm <sup>2</sup>	6	21	21
Pressione - Pressure	bar	417	119	143

**Art. 800B** (Art. 800A + Art.393) Morsa + centralina a comando manuale singolo / Vise + power unit with single manual control

E1	273	373	370,5	470,5	570,5	670,5	485	585
Cod.	5.80.0B120	5.80.0B130	5.80.0B230	5.80.0B240	5.80.0B250	5.80.0B260	5.80.0B340	5.80.0B350

**Art. 800D** (Art. 800 + 802) Morsa + moltiplicatore di coppia / Vise + torque multiplier

E2	277	377	360	460	560	660	470	570
Nm	Max 20		Max 25			Max 20		
Cod.	5.80.0D120	5.80.0D130	5.80.0D230	5.80.0D240	5.80.0D250	5.80.0D260	5.80.0D340	5.80.0D350

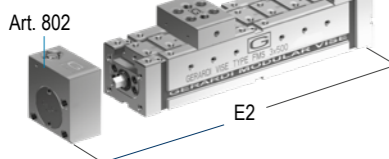

Moltiplicatore di coppia con rinvio angolare - Mechanical with torque multiplier with angular transmission

**Art. 802** Chiave dinamometrica Art.357 (Consigliata) - Torque wrench Art.357 (Suggested)

Cod.	5.80.21000	5.80.22000	5.80.23000
------	------------	------------	------------

- Dotazione standard:
- 2 arresti laterali Art. 370
  - 1 coppia di tasselli di posizionamento per cava da 16 mm Art. 297
  - 1 chiave a pipa Art. 375

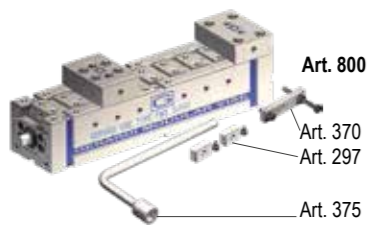

- Standard equipment:
- 2 workstops Art. 370
  - 1 pair of positioning key-nuts for 16 mm slot Art. 297
  - 1 box wrench Art. 375

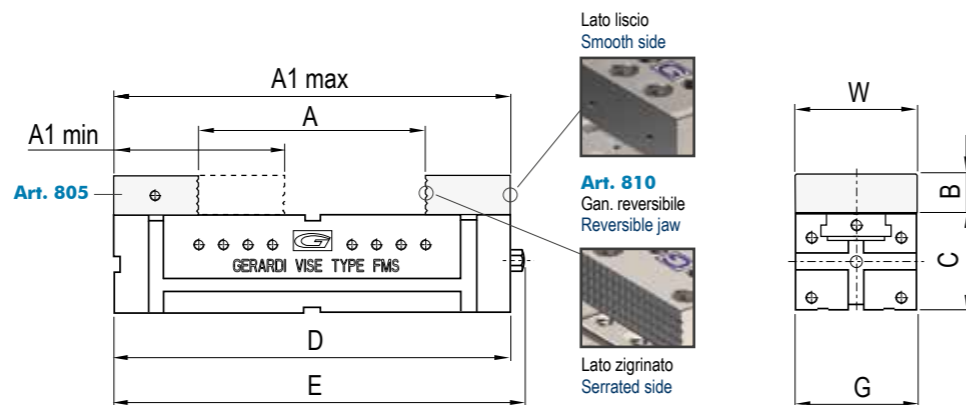

	3 30 kN			4 30 kN				5 32 kN			6 32 kN		
A	430	530	630	300	400	500	600	380	480	580	580	680	780
A1	170 / 600	170 / 700	170 / 800	200 / 500	200 / 600	200 / 700	200 / 800	220 / 600	220 / 700	220 / 800	220 / 800	220 / 800	220 / 100
B	40			50				60			60		
C	100			120				140			160		
D	600	700	800	500	600	700	800	600	700	800	800	900	1000
E	625	725	825	525	625	725	825	625	725	825	825	925	1025
G	125			145				170			190		
W	124			144				169			189		
kg	50	55	60	66	72	80	88	115	125	135	170	190	210
Cod.	5.80.03600	5.80.03700	5.80.03800	5.80.04500	5.80.04600	5.80.04700	5.80.04800	5.80.05600	5.80.05700	5.80.05800	5.80.06800	5.80.06900	5.80.06100

**Art. 800A** Meccanica con predisposizione idraulica solo per serraggi singoli / Mechanical with prepared hydraulic connection only for single clamping

E1	685	785	885	585	685	785	885	-	-	-	-	-	-
Cod.	5.80.0A360	5.80.0A370	5.80.0A380	5.80.0A450	5.80.0A460	5.80.0A470	5.80.0A480	5.80.0A560	5.80.0A570	5.80.0A580	5.80.0A680	5.80.0A690	5.80.0A610

**Art. 882A** Connettore Idraulico - Hydraulic Connexion

	10	10	-	-
	21	21	-	-
	143	143	-	-

**Art. 800B** (Art. 800A + Art.393) Morsa + centralina a comando manuale singolo / Vise + power unit with single manual control

E1	685	785	885	585	685	785	885	-	-	-	-	-	-
Cod.	5.80.0B360	5.80.0B370	5.80.0B380	5.80.0B450	5.80.0B460	5.80.0B470	5.80.0B480	5.80.0B560	5.80.0B570	5.80.0B580	5.80.0B680	5.80.0B690	5.80.0B610

**Art. 800D** (Art. 800 + 802) Morsa + moltiplicatore di coppia / Vise + torque multiplier

E2	670	770	870	570	670	770	870	685	785	885	-	-	-	
Nm	Max 20		Max 20			Max 20			Max 20			Max 20		
Cod.	5.80.0D360	5.80.0D370	5.80.0D380	5.80.0D450	5.80.0D460	5.80.0D470	5.80.0D480	5.80.0D560	5.80.0D570	5.80.0D580	5.80.0D680	5.80.0D690	5.80.0D610	

**Art. 802** Moltiplicatore di coppia con rinvio angolare - Mechanical with torque multiplier with angular transmission

Cod.	5.80.23000	5.80.24000	5.80.25000	5.80.26000
------	------------	------------	------------	------------

**Art. 800**

Art.	Pag.	Art.	Pag.
<b>800E</b>	5.61	<b>850B</b>	5.61
<b>800I</b>	5.61	-	-
<b>801</b>	5.50	-	-
<b>801G</b>	5.61	-	-
<b>8011</b>	5.61	-	-
<b>805</b>	5.54	-	-
<b>810</b>	5.56	-	-
<b>818</b>	5.52	-	-
<b>821</b>	5.53	-	-
<b>823B</b>	5.59	-	-
<b>825B</b>	5.59	-	-

Tipo (grandezza) morsa / Vise type (size)	kN	1					2					3 30 kN	
Apertura massima / Maximum opening	A	-	-	-	-	-	-	-	-	-	-	232	332
	B	-	-	-	-	-	-	-	-	-	-	40	-
	C	-	-	-	-	-	-	-	-	-	-	100	-
	D	-	-	-	-	-	-	-	-	-	510	610	-
	E	-	-	-	-	-	-	-	-	-	400	500	-
	G	-	-	-	-	-	-	-	-	-	-	125	-
	W	-	-	-	-	-	-	-	-	-	-	124	-
	kg	-	-	-	-	-	-	-	-	-	-	-	44
	Cod.	-	-	-	-	-	-	-	-	-	5.90.03400	5.90.03500	-



Questa morsa, pur essendo parte del programma FMS, non è predisposta per serraggi doppi o autocentranti

Art. 900Y	Cod.	1	2	3 30 kN
Modulo per serraggio idraulico Module for hydraulic clamping		-	-	5.90.0Y300

	3 30 kN			4 30 kN				5 32 kN			6		
A	432	532	632	304	404	505	605	384	484	584	-	-	-
B	40	-	-	50	-	-	-	60	-	-	-	-	-
C	100	-	-	120	-	-	-	140	-	-	-	-	-
D	710	810	910	610	710	810	910	710	810	910	-	-	-
E	600	700	800	500	600	700	800	600	700	800	-	-	-
G	125	-	-	145	-	-	-	170	-	-	-	-	-
W	124	-	-	144	-	-	-	169	-	-	-	-	-
kg	-	-	-	57	-	-	-	99	-	-	-	-	-
Cod.	5.90.03600	5.90.03700	5.90.03800	5.90.04500	5.90.04600	5.90.04700	5.90.04800	5.90.05600	5.90.05700	5.90.05800	-	-	-

This type of vise even if it is part of the FMS series is not suitable for double or self-centering clamping

Art. 900Y	Cod.	3 30 kN	4 30 kN	5 32 kN	6
		5.90.0Y300	5.90.0Y300	5.90.0Y300	-

5 FUNZIONAMENTO LIMITATORE DI FORZA - HOW TO USE THE LIMITING DEVICE

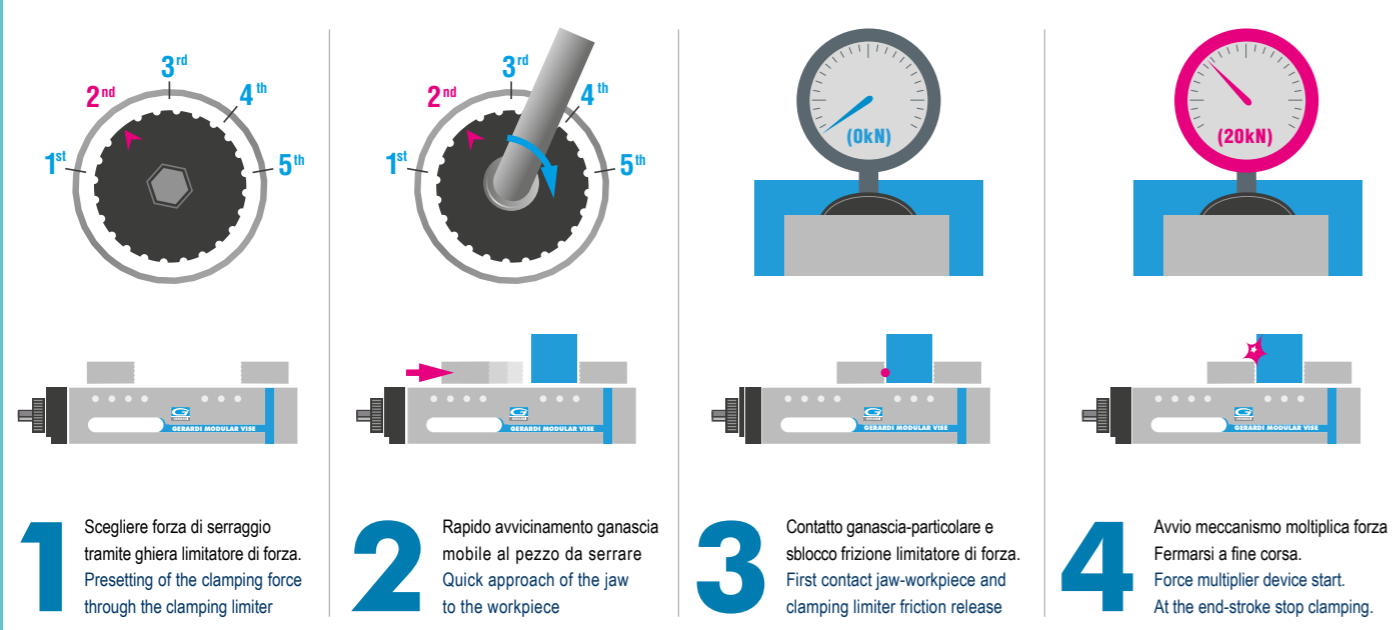

5 Diagrammi forze di serraggio - Diagrams with clamping force

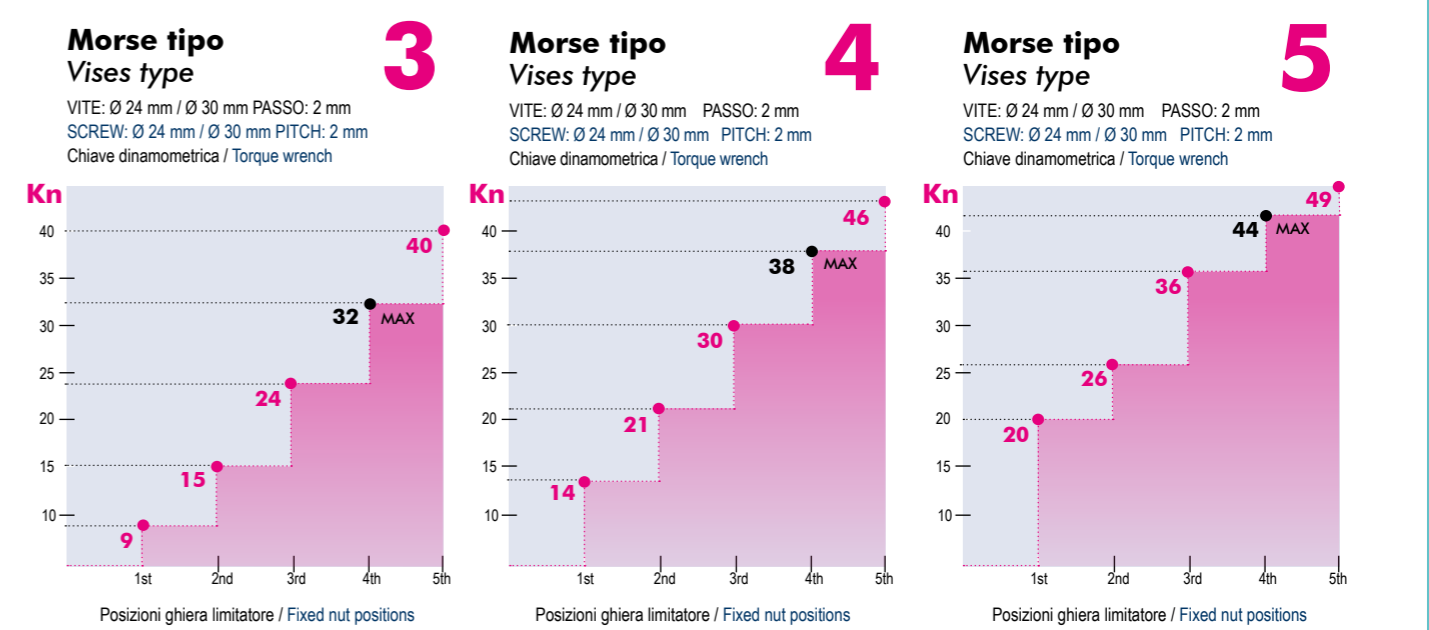

- Dotazione standard:
- 2 arresti laterali Art. 370
  - 1 coppia di tasselli di posizionamento per cava da 16 mm Art. 297
  - 1 chiave a pipa Art. 375

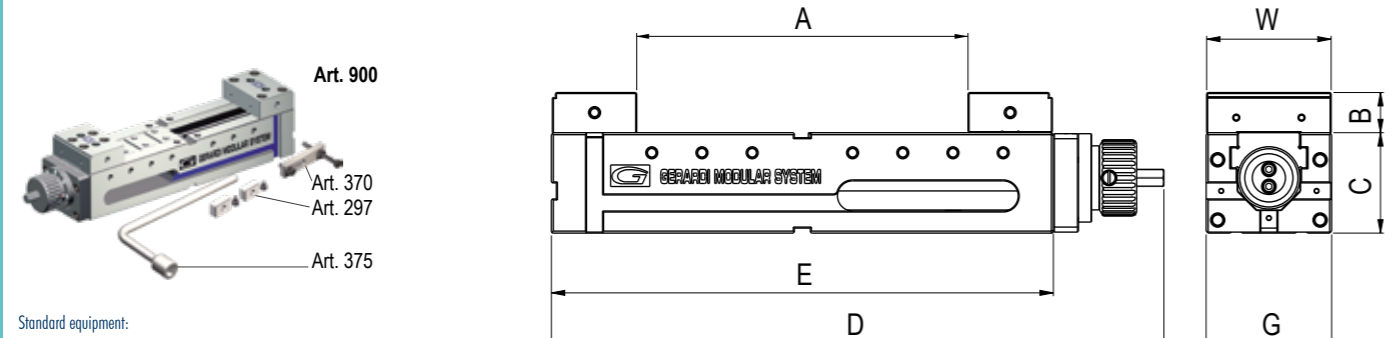

- Standard equipment:
- 2 workstops Art. 370
  - 1 pair of positioning key-nuts for 16 mm slot Art. 297
  - 1 box wrench Art. 375

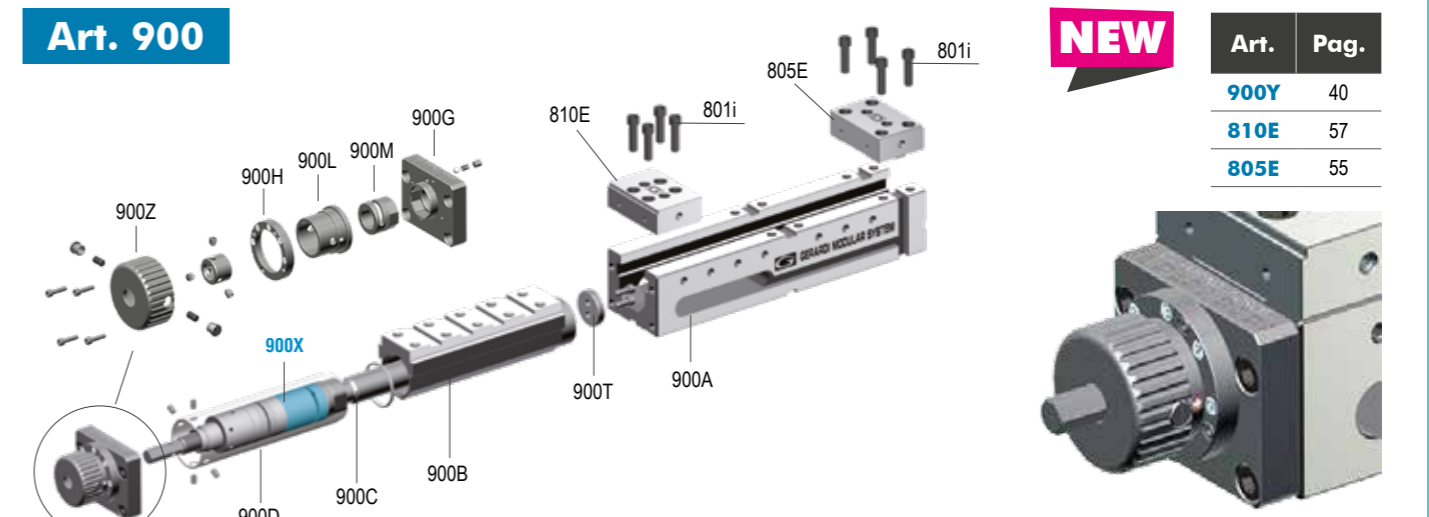

Art.	Pag.
900Y	40
810E	57
805E	55

Art.900X= Modulo per serraggio meccanico - Module for mechanical clamping

Tipo (grandezza) morsa / Vise type (size)		1 25 kN		2 25 kN				3 30 kN		
Apertura massima / Max. opening		A	85	185	170	270	370	470	230	330
<b>Art. 800C</b>		A1	115	130				170		
		B	25	30				40		
		D	200	300	300	400	500	600	400	500
		E	232	332	320	420	520	620	425	525
		G1	120	175				210		
		L	300	350				400		
		M	33	33				38		
		W	74	94				124		
		kg	30	45	53	70	88	106	90	112



FMS vise tower with straight jaws for 4 clamping stations

**SPECIFICA SOLO PER SERRAGGI SINGOLI**  
SPECIFIC FOR SINGLE CLAMPING ONLY

Cod.	5.80.0C120	5.80.0C130	5.80.0C230	5.80.0C240	5.80.0C250	5.80.0C260	5.80.0C340	5.80.0C350
------	------------	------------	------------	------------	------------	------------	------------	------------

Questa morsa, pur essendo parte del programma FMS, non è predisposta per serraggi doppi o autocentranti

**Art. 800G**  
Modulo base cubo morsa FMS (senza ganasce)  
FMS vise tower base (without jaws)

**NEW**  
22/23

Cod.	5.80.0G120	5.80.0G130	5.80.0G230	5.80.0G240	5.80.0G250	5.80.0G260	5.80.0G340	5.80.0G350
------	------------	------------	------------	------------	------------	------------	------------	------------

		3 30 kN			4 30 kN				5 32 kN			6 32 kN		
A		430	530	630	300	400	500	600	380	480	580	480	580	680
A1		170			509				630			810		
B		40			50				60			60		
D		600	700	800	500	600	700	800	600	700	800	800	900	1000
E		625	725	825	525	625	725	825	625	725	825	825	925	1025
G1		210			245				280			290		
L		400			450				500			550		
M		38			38				38			38		
W		124			144				169			189		
kg		135	157	180	180	210	252	288	260	303	340	500	562	625

Cod.	5.80.0C360	5.80.0C370	5.80.0C380	5.80.0C450	5.80.0C460	5.80.0C470	5.80.0C480	5.80.0C560	5.80.0C570	5.80.0C580	5.80.0C680	5.80.0C690	5.80.0C610
------	------------	------------	------------	------------	------------	------------	------------	------------	------------	------------	------------	------------	------------

This type of vise even if it is part of the FMS series is not suitable for double or self-centering clamping

Cod.	5.80.0G360	5.80.0G370	5.80.0G380	5.80.0G450	5.80.0G460	5.80.0G470	5.80.0G480	5.80.0G560	5.80.0G570	5.80.0G580	5.80.0G680	5.80.0G690	5.80.0G610
------	------------	------------	------------	------------	------------	------------	------------	------------	------------	------------	------------	------------	------------

**GANASCE REVERSIBILI  
REVERSIBLE JAWS**

**Art. 810**

**Art. 805**

**Art. 828A extra**

**Art. 805**

**Art. 805**

**Art. 810**

**Art. 805**

**Datazione standard per Art. 800C**

- 1 chiave a pipa Art. 375
- 4 arresti laterali Art. 370
- 2 coppie di tasselli di posizionamento per cava da 16 mm Art. 297
- 1 galfare di sollevamento Art. 848
- Imballo in cassa di legno

**Standard equipment for Art. 800C**

- 1 box wrench Art. 375
- 4 workstops Art. 370
- 2 pair of positioning key-nuts for 16 mm slot Art. 297
- 1 lifting hook Art. 848
- Wooden box packaging

**GANASCE REVERSIBILI  
REVERSIBLE JAWS**

**Art. 800C**

**Esplso di cubo-morsa FMS con ganasce piane per il serraggio di 4 pezzi**  
Explose of FMS vise tower with straight jaws for 4 clamping stations

Art.	Pag.	Art.	Pag.
<b>800I</b>	5.61	-	-
<b>801G</b>	5.61	-	-
<b>801I</b>	5.61	-	-
<b>810</b>	5.56	-	-
<b>818</b>	5.52	-	-
<b>821</b>	5.53	-	-
<b>823B</b>	5.59	-	-
<b>825B</b>	5.59	-	-
<b>850B</b>	5.61	-	-
-	-	-	-
-	-	-	-

Tipo (grandezza) morsa / Vise type (size)	kN	1 25 kN		2 25 kN				3 30 kN	
Apertura massima / Max. opening	A	2 x 16	2 x 66	2 x 54	2 x 104	2 x 154	2 x 204	2 x 74	2 x 124
	B	25		30				40	
	D	200	300	300	400	500	600	400	500
	E	232	332	320	420	520	620	425	525
	G1	120		175				210	
	L	300		350				400	
	M	33		33				38	
	W	74		94				124	
	kg	30	45	53	70	88	106	90	112
	Cod.	5.86.0C120	5.86.0C130	5.86.0C230	5.86.0C240	5.86.0C250	5.86.0C260	5.86.0C340	5.86.0C350

**Art. 860C**

Cubo-morsa FMS doppio per il serraggio di 8 pezzi



Double FMS vise tower for 8 clamping stations

**Art. 855C**

Modulo base cubo morsa FMS doppia (senza ganasce)  
FMS Double vise tower base (without jaws)

Cod.	5.85.5C120	5.85.5C130	5.85.5C230	5.85.5C240	5.85.5C250	5.85.5C260	5.85.5C340	5.85.5C350

	3 30 kN			4 30 kN				5 32 kN			6 32 kN		
A	2 x 174	2 x 224	2 x 274	2 x 103	2 x 153	2 x 203	2 x 253	2 x 138	2 x 188	2 x 238	2 x 238	2 x 288	2 x 338
B	40			50				60			60		
D	600	700	800	500	600	700	800	600	700	800	800	900	1000
E	625	725	825	525	625	725	825	625	725	825	825	925	1025
G1	210			245				280			290		
L	400			450				500			550		
M	38			38				38			38		
W	124			144				169			189		
kg	135	157	180	180	210	252	288	260	303	340	500	562	625
Cod.	5.86.0C360	5.86.0C370	5.86.0C380	5.86.0C450	5.86.0C460	5.86.0C470	5.86.0C480	5.86.0C560	5.86.0C570	5.86.0C580	5.86.0C680	5.86.0C690	5.86.0C610

Cod.	5.85.5C360	5.85.5C370	5.85.5C380	5.85.5C450	5.85.5C460	5.85.5C470	5.85.5C480	5.85.5C560	5.85.5C570	5.85.5C580	5.85.5C680	5.85.5C690	5.85.5C610

**GANASCE REVERSIBILI  
REVERSIBLE JAWS**

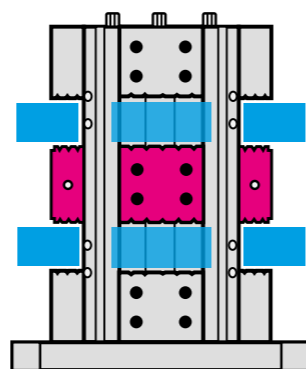
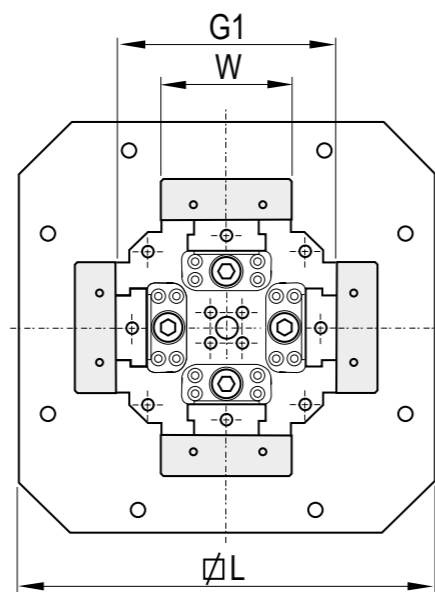
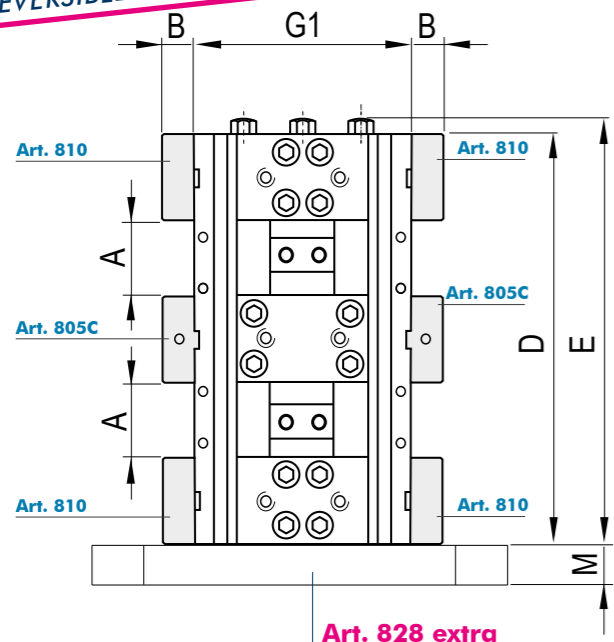

Dotazione standard per Art. 860C

- 1 chiave a pipa Art. 375
- 4 arresti laterali Art. 370
- 2 coppie di tasselli di posizionamento per cava da 16 mm Art. 297
- 1 golphare di sollevamento Art. 848
- Imballo in cassa di legno
- Meccanismo 3a mano

Standard equipment for Art. 860C

- 1 box wrench Art. 375
- 4 workstops Art. 370
- 2 pair of positioning key-nuts for 16 mm slot Art. 297
- 1 lifting hook Art. 848
- Wooden box packaging
- Third hand device

**GANASCE REVERSIBILI  
REVERSIBLE JAWS**

**Art. 860C**

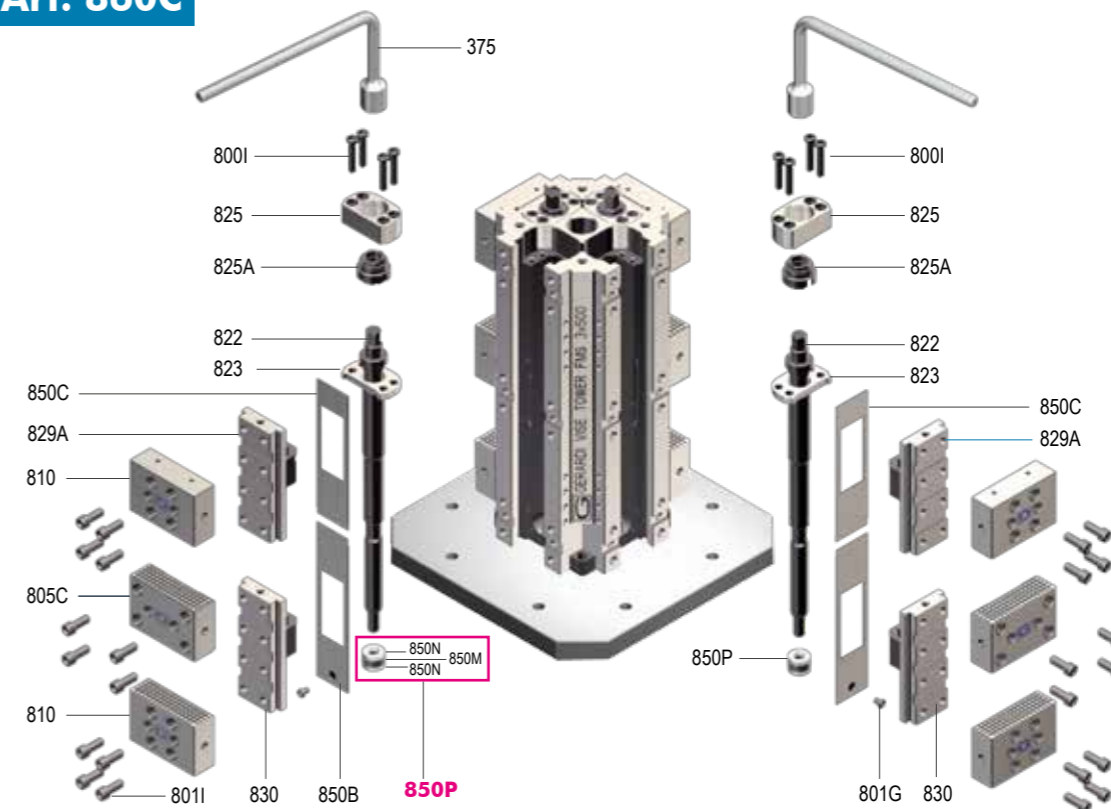

Art.	Pag.
375	4.35
8001	5.61
801G	5.61
8011	5.61
805C	5.54
810	5.56
822	5.53
823	5.59
825	5.59
825A	5.61
829A	5.52
830	5.52
850B	5.61
850C	5.61
850P	5.61
-	-
-	-

Tipo (grandezza) morsa / Vise type (size)		1 25 kN		2 25 kN				3 30 kN	
kN		25 kN		25 kN				30 kN	
A	Apertura massima Max. opening	2 x 60	2 x 110	2 x 118	2 x 168	2 x 218	2 x 268	2 x 162	2 x 212

**Art. 863C**

Cubo morsa  
FMS doppio con  
ganasse a gradino  
per il serraggio  
di 8 pezzi



Double FMS vise  
tower with step-type  
jaws for 8 clamping  
stations

Cod.	5.86.3C120	5.86.3C130	5.86.3C230	5.86.3C240	5.86.3C250	5.86.3C260	5.86.3C340	5.86.3C350

Ø Apertura Minima / Massima Ø Minimum - Max Opening		10 / 25		10 / 50				25 / 100	
A		10 / 25		10 / 50				25 / 100	

**Art. 870C**

Cubo morsa  
FMS autocentrante  
con ganasse  
prismatiche

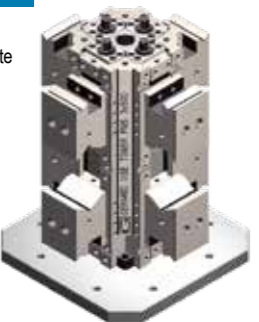

Self-centering FMS vise  
tower with prismatic  
jaws

Cod.	5.87.0C120	5.87.0C130	5.87.0C230	5.87.0C240	5.87.0C250	5.87.0C260	5.87.0C340	5.87.0C350

D	200	300	300	400	500	600	400	500
E	232	332	320	420	520	620	425	525
G1	120			175			210	
L	300			350			400	
M	33			33			38	
W	74			94			124	
W1	60			75			100	
kg	42	63	68	90	113	130	118	147

3 30 kN		4 30 kN				5 32 kN			6 32 kN				
A	2 x 262	2 x 312	2 x 362	2 x 204	2 x 254	2 x 304	2 x 354	2 x 254	2 x 304	2 x 354	2 x 354	2 x 404	2 x 454

Cod.	5.86.3C360	5.86.3C370	5.86.3C380	5.86.3C450	5.86.3C460	5.86.3C470	5.86.3C480	5.86.3C560	5.86.3C570	5.86.3C580	5.86.3C680	5.86.3C690	5.86.3C610

A		25 / 100		30 / 150				35 / 200			40 / 300		
A		25 / 100		30 / 150				35 / 200			40 / 300		

Cod.	5.87.0C360	5.87.0C370	5.87.0C380	5.87.0C450	5.87.0C460	5.87.0C470	5.87.0C480	5.87.0C560	5.87.0C570	5.87.0C580	5.87.0C680	5.87.0C690	5.87.0C610

D	600	700	800	500	600	700	800	600	700	800	800	900	1000
E	625	725	825	525	625	725	825	625	725	825	825	925	1025
G1		210			245				280			290	
L		400			450				500			550	
M		38			38				38			38	
W		124			144				169			189	
W1		100			132				140			160	
kg	177	206	236	242	290	339	388	328	383	437	656	738	820

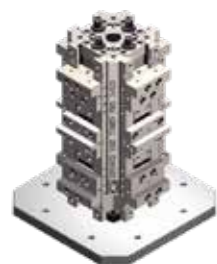
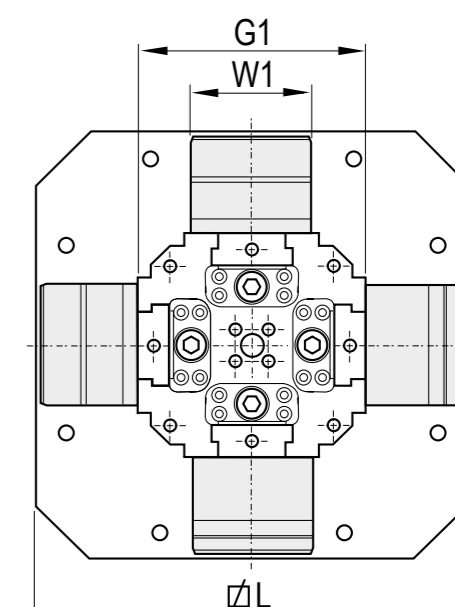
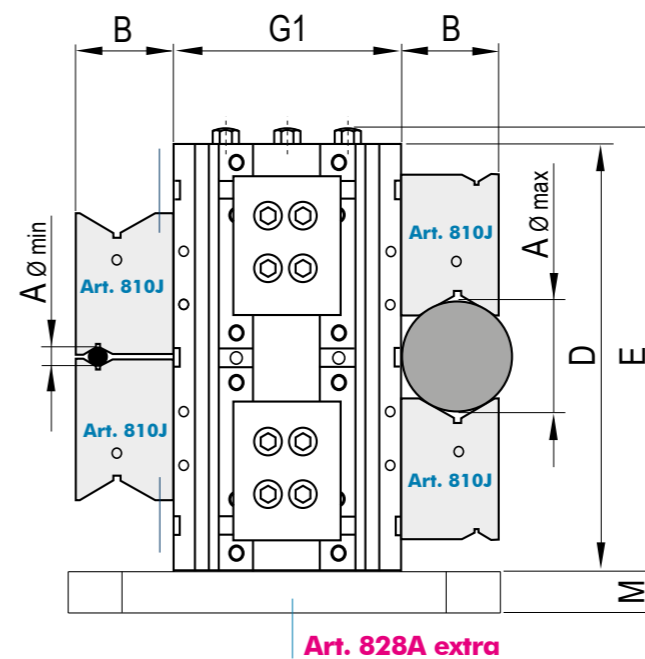
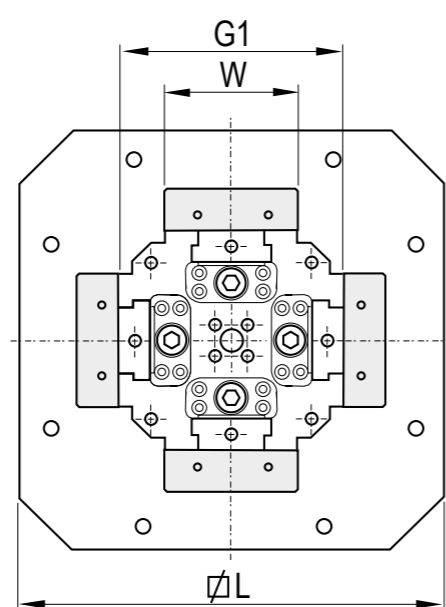
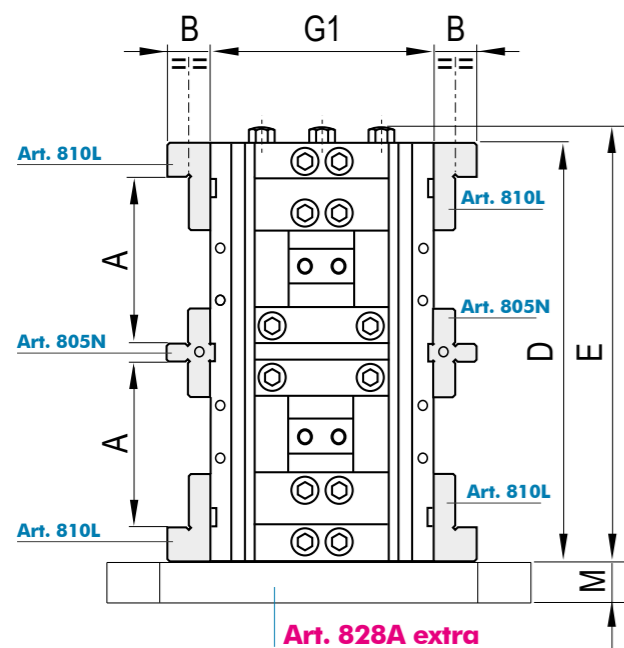

Dotazione standard per Art. 860C

- 1 chiave a pipa Art. 375
- 4 arresti laterali Art. 370
- 2 coppie di tasselli di posizionamento per cava da 16 mm Art. 297
- 1 lifting hook Art. 848
- 1 goliere di sollevamento Art. 848
- Imballo in cassa di legno
- Meccanismo 3a mano

Standard equipment for Art. 860C

- 1 box wrench Art. 375
- 4 workstops Art. 370
- 2 pair of positioning key-nuts for 16 mm slot Art. 297
- 1 lifting hook Art. 848
- Wooden box packaging
- Third hand device

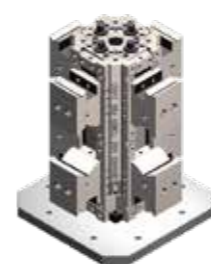
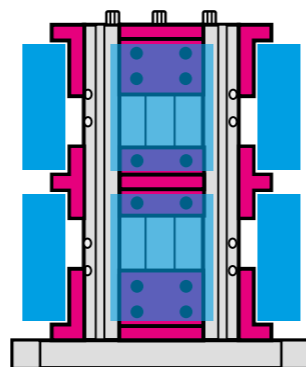

Dotazione standard per Art. 863C e Art. 870C:

- 1 chiave a pipa Art. 375
- 4 arresti laterali Art. 370
- 2 coppie di tasselli di posizionamento per cava da 16 mm Art. 297
- 1 goliere di sollevamento Art. 848
- Imballo in cassetta di legno
- Meccanismo 3a mano

Standard equipment for Art. 863C and Art. 870C:

- 1 box wrench Art. 375
- 4 workstops Art. 370
- 2 pair of positioning key-nuts for 16 mm slot Art. 297
- 1 lifting hook Art. 848
- Packaging wooden box
- Third hand device

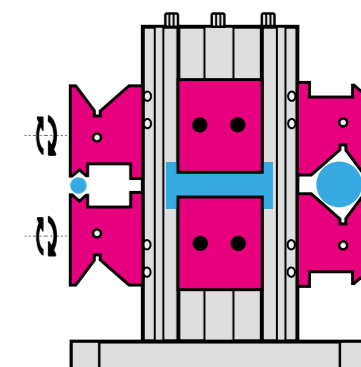



**COMPONENTI PER CUBO FMS**  
**SPARE PARTS FOR FMS CUBE**

**Art. 855C**



Precisione / Accuracy  
**±0,02mm**

Durezza / Hardened  
**HRC 58±2**

- 1** Art.8001  
**VITI PER GANASCE**  
SCREWS FOR JAWS
- 2** Art.825A  
**GHIERA**  
NUT
- 3** Art.825B  
**PIASTRA DI CONTENIMENTO**  
SCREW HOLDING PLATE
- 4** Art.823  
**PIASTRA INTERMEDIA**  
MIDDLE PLATE
- 5** Art.804  
**CORPO BASE CUBO**  
CUBE BASE BODY
- 6** Art.822  
**VITE DI BLOCCAGGIO**  
MAIN SCREW
- 7** Art.850C  
**RIPARO**  
PROTECTION
- 8** Art.850B  
**RIPARO LATO VITE**  
PROTECTION SIDE SCREW
- 9** Art.830  
**SLITTA FILETTO DESTRO**  
SLIDE WITH RIGHT THREAD
- 10** Art.829A  
**SLITTA FILETTO SINISTRO**  
SLIDE WITH LEFT THREAD
- 11** Art.850P  
**DISPOSITIVO TERZA MANO**  
THIRD HAND DEVICE

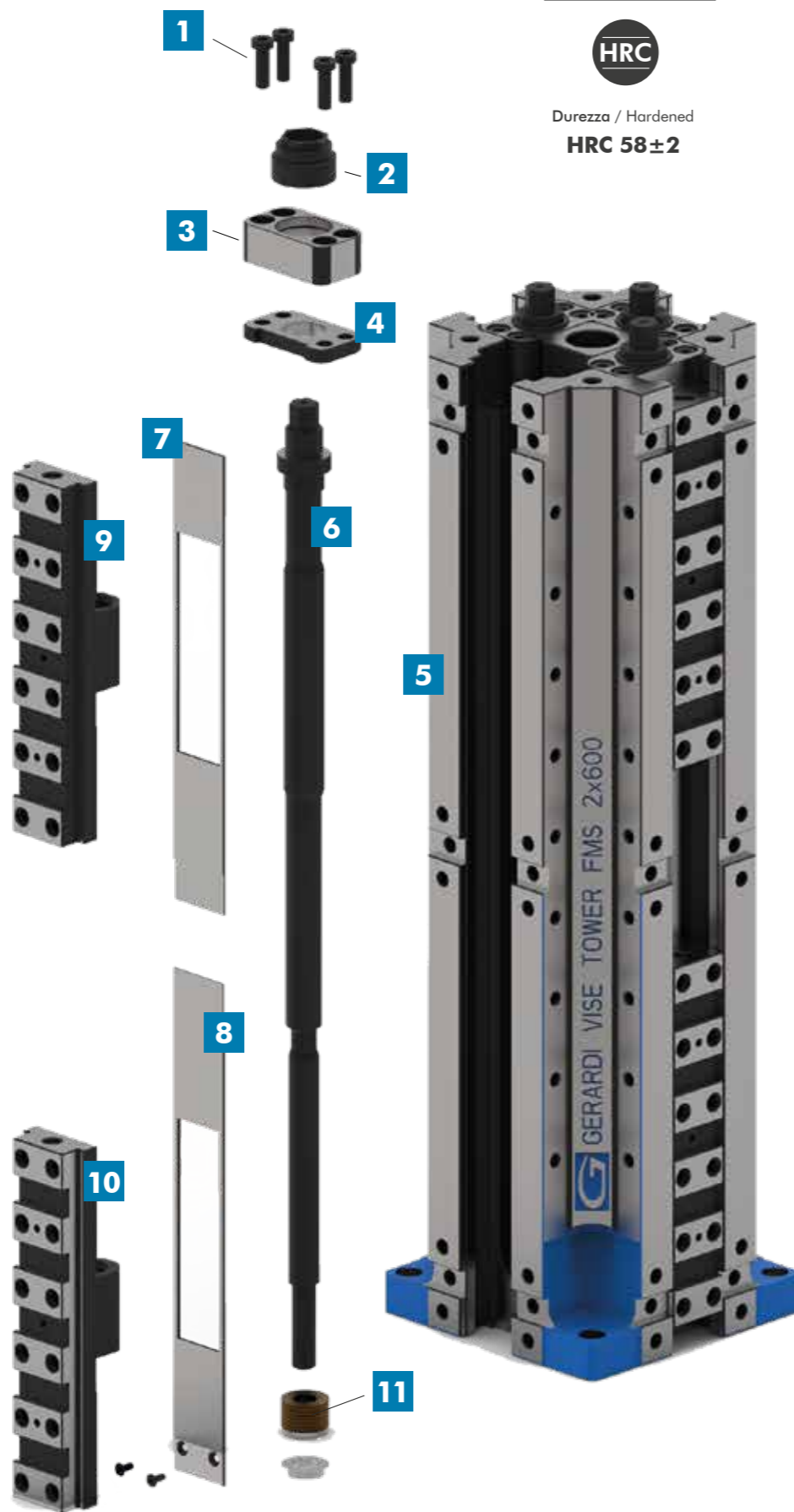

Tipo (grandezza) Type (size)	1		2		3		4		5		6										
Larghezza base / Base length	200	300	300	400	500	600	400	500	600	700	800	500	600	700	800	600	700	800	800	900	1000
Cod.	5.80.41200	5.80.41300	5.80.42300	5.80.42400	5.80.42500	5.80.42600	5.80.43400	5.80.43500	5.80.43600	5.80.43700	5.80.43800	5.80.44500	5.80.44600	5.80.44700	5.80.44800	5.80.45600	5.80.45700	5.80.45800	5.80.46800	5.80.46900	5.80.46100

**Art. 804**  
Corpo base cubo FMS.  
Disegni e tabella dimensionale  
FMS cube base body.  
Drawing and table dimension

	200	300	300	400	300	400	400	500	600	700	800	500	600	700	800	600	700	800	800	900	1000
D	200	300	300	400	300	400	400	500	600	700	800	500	600	700	800	600	700	800	800	900	1000
F	140			175					210				245				280			290	
H	71	121	117	167	217	267	157	207	257	307	357	200	250	300	350	245	295	345	345	395	445
I	10			13					13				20				20			20	
J	10			12					12				18				18			18	
K	13			13					13				20				20			20	
L	21			25					35				42				47			47	
M	16			16					16				16				16			16	
N	45			53					76				86				96			110	
O	35			41					61				71				81			94	
P	M10			M12					M12				M16				M16			M20	
Q	11			13					13				13				17			17	
R	-			100					120				150				150			150	
S	-			40					40				40				50			50	
T	-			120					16				16				16			210	
U	M8			M10					M12				M16				M16			M20	
V	M8			M10					M12				M12				M12			M12	
Z	M10			M10					M10				M10				M10			M10	
X	75			95					125				145				170			190	
Y	70			85					110				125				140			130	
AB	32			40					50				60				68			68	
AC	56			70					92				108				126			144	
AD	56			68					92				106				126			144	
AE	50	70		70					100				100				100			125	
AF	10	25		50					50				50				50			50	
AG	49			62					62				80				95			105	
AH	41			53					72				70				82			95	

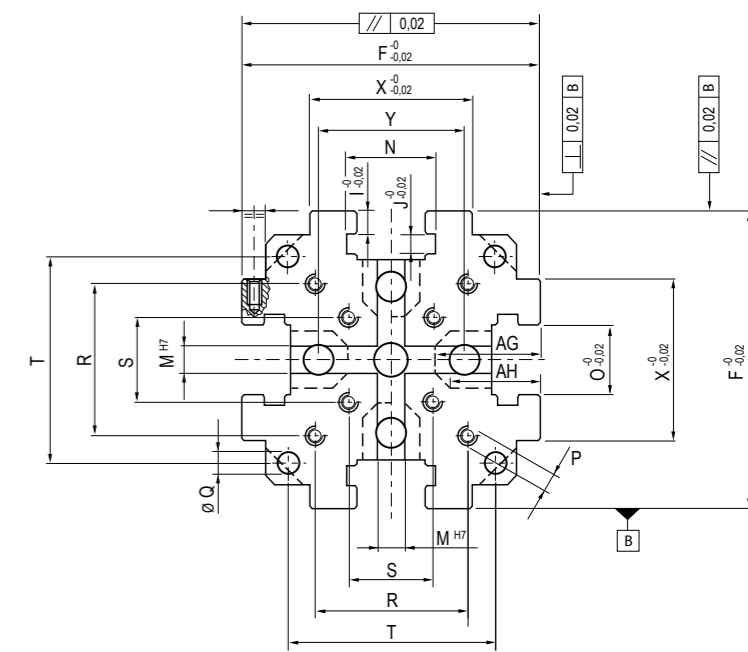
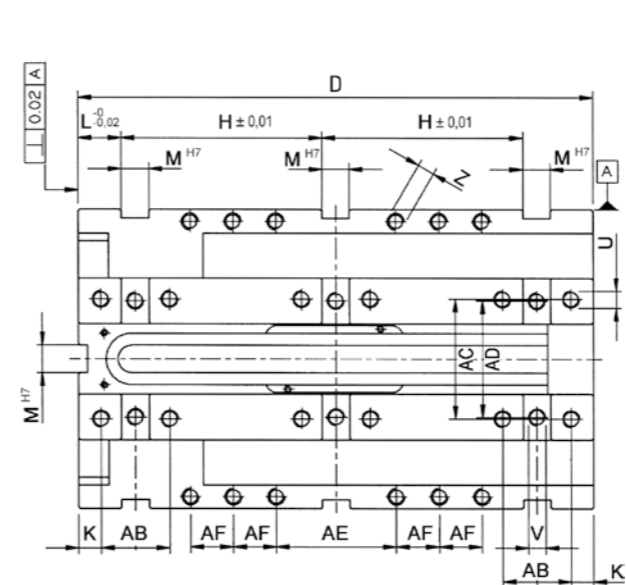

**Tipo (grandezza) morsa / Vise type (size)**

**Art. 801** Base morsa FMS. Disegni e tabella dimensionale  
FMS vise base body. Drawing and table dimension

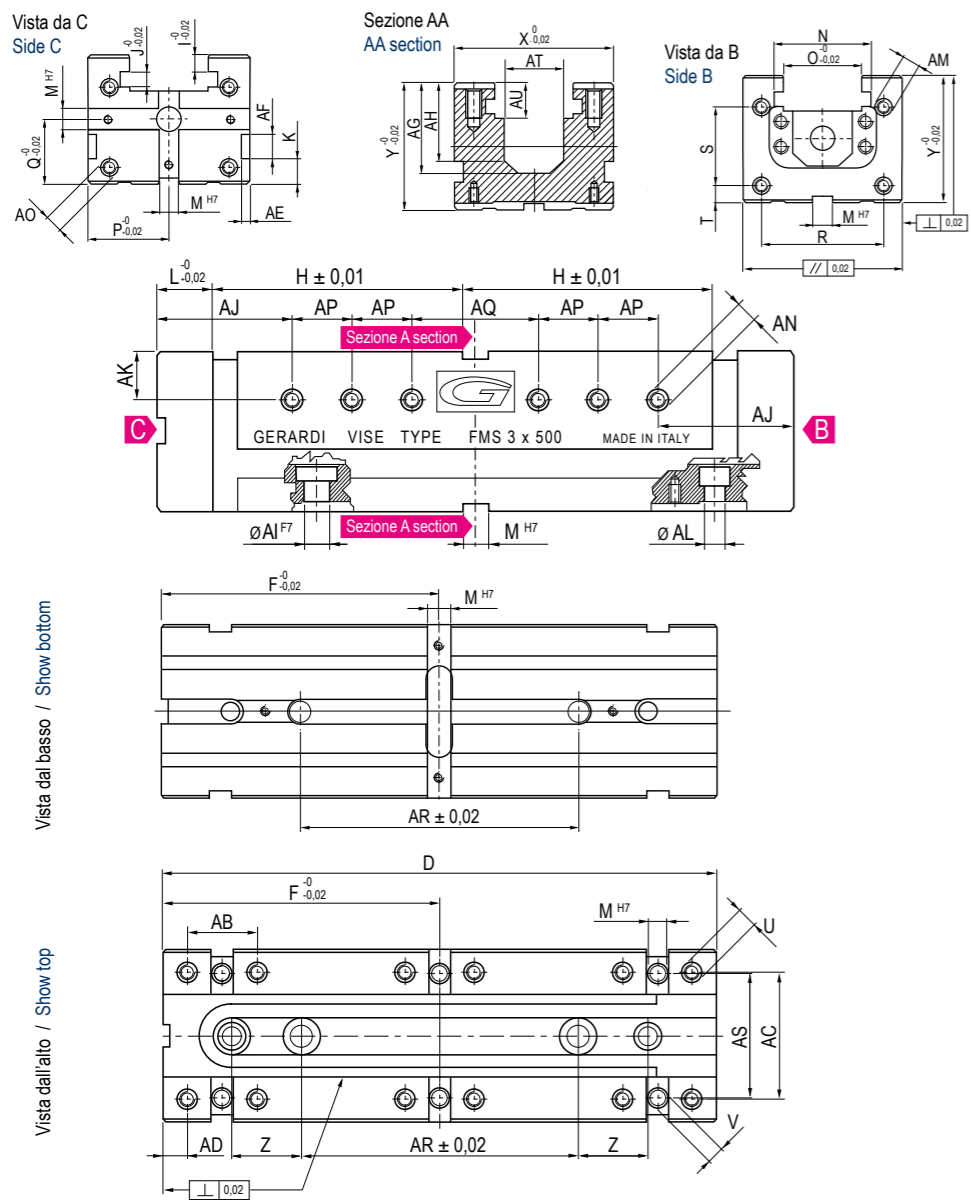

	1		2	
kg	4,7	7,3	12,8	19
Cod.	5.80.11200	5.80.11300	5.80.12300	5.80.12400
D	200	300	300	400
F	100	150	150	200
H	71	121	117	167
I	10		13	
J	10		12	
K	15		20	
L	21		25	
M	16		16	
N	45		53	
O	35		41	
P	37,5		47,5	
Q	35		45	
R	52		70	
S	30		48	
T	20		22	
U	M8		M10	
V	M8		M10	
Z	50		50	
X	75		95	
Y	70		90	
AB	32		40	
AC	56		70	
AD	13		13	
AE	4		6	
AF	16		16	
AG	49		62	
AH	41		53	
AI	Ø 16 X 2		Ø 16 X 2	
AJ	55		65	
AK	20		27	
AL	Ø 11		Ø 13	
AM	n°0 M10	n°2 M10	n°2 M10	n°2 M10
AN	n°8 M10	n°12 M10	n°12 M10	n°16 M10
AO	M10		M10	
AP	20	25	50	
AQ	50	70	70	
AR	100	200	200	
AS	56		68	
AT	28		34	
AU	23		28	

**PIASTRE D'INTERFACCIA ZERO POINT**

**Tipo (grandezza) / Type (size)**

**Art. 62**  
**FMS**

Piastra di interfaccia  
Zero Point per morse FMS

Zero Point connecting  
plate for FMS vises

Tiranti e viti INCLUSI  
Pull Studs and screws INCLUDED

**Art. 81P**

Piastra Zero Point in acciaio con montaggio incassato  
Zero Point steel plate built-in mounting

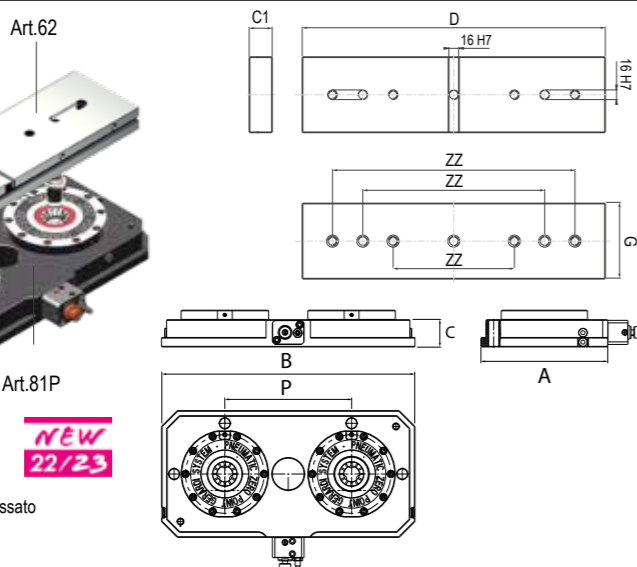

	1		2	
D	232	332	300	400
G	75		95	
C1	38		38	
ZZ	200 / 300		200 / 300 / 400	
kg	5	7	11	13,4
Cod.	5.62.12000	5.62.13000	5.62.23000	5.62.24000
A	200		200	
B	400		400	
C	43		43	
Art. 665	Tipo / Type T.2		Tipo / Type T.2	
P	200		200	
kg	29		29	
Cod.	9.81.P2040S2		9.81.P2040S2	

	2		3				4				5			6			
kg	23	27	26	31	39	46	52	47	56	65	75	71	82	94	140	156	174
Cod.	5.80.12500	5.80.12600	5.80.13400	5.80.13500	5.80.13600	5.80.13700	5.80.13800	5.80.14500	5.80.14600	5.80.14700	5.80.14800	5.80.15600	5.80.15700	5.80.15800	5.80.16800	5.80.16900	5.80.16100
D	500	600	400	500	600	700	800	500	600	700	800	600	700	800	800	900	1000
F	250	300	200	250	300	350	400	250	300	350	400	300	350	400	400	450	500
H	217	267	157	207	257	307	357	200	250	300	350	245	295	345	345	395	445
I	13				13					20			20				
J	12				12					18			18				
K	20				20					20			26				
L	25				35					42			47				
M	16				16					16			16				
N	53				76					86			96				110
O	41				61					71			82				94
P	47,5				62,5					72,5			85				95
Q	45				50					60			70				80
R	70				92					108			126				144
S	48				62					72			92				100
T	22				13					16			18				20
U	M10				M12					M16			M16				M20
V	M10				M12					M12			M12				M12
Z	50				50					50			50				50
X	95				125					145			170				190
Y	90				100					120			140				160
AB	40				50					60			68				68
AC	70				92					108			126				144
AD	13				18					20			21				20
AE	6				6					10			10				10
AF	16				16					16			16				16
AG	62				72					80			95				105
AH	53				62					70			82				95
AI	Ø 16 x 2				Ø 16 x 2					Ø 16 x 2			Ø 16 x 2				Ø 16 x 2
AJ	65				100					100			100				125
AK	27				32					40			48				58
AL	Ø 13				Ø 13					Ø 13			Ø 17				Ø 17
AM	n°4 M10	n°6 M10	n°2 M12	n°4 M12	n°6 M12	n°8 M10M	n°10 M10	n°4 M12	n°6 M12	n°8 M10	n°10 M10	n°6 M16	n°8 M16	n°10 M10	n°10 M16	n°12 M20	n°14 M20
AN	n°20 M10	n°24 M10	n°8 M12	n°12 M12	n°16 M16	n°20 M20	n°24 M24	n°12 M16	n°16 M16	n°20 M20	n°24 M24	n°16 M16	n°20 M16	n°24 M24	n°24 M24	n°28 M28	n°32 M32
AO	M10				M12					M16			M16				M20
AP	50				50					50			50				50
AQ	70				100					100			100				125
AR	200				200					200			400	400	600	400	400
AS	68				92					106			126				144
AT	34				44					44			52				49
AU	28				28					41			41				41

**ZERO POINT CONNECTING PLATES**

	2		3				4				5			6			
D	500	600	400	500	600	700	800	500	600	700	800	600	700	800	800	900	1000
G	95				125					145			170				190
C1	38				38					38			38				38
ZZ	200 / 300 / 400				200 / 300 / 400					200 / 300 / 400			200 / 300 / 400				200 / 300 / 400
kg	16,1	18,9	13,9	17,8	21,5	25,1	28,5	20,8	25	29,3	33,5	29	34	39	44	49	55
Cod.	5.62.25000	5.62.26000	5.62.34000	5.62.35000	5.62.36000	5.62.37000	5.62.38000	5.62.45000	5.62.46000	5.62.47000	5.62.48000	5.62.56000	5.62.57000	5.62.58000	5.62.68000	5.62.69000	5.62.61000
A	200				200			200		200			200				250
B	600				400			500		600			600				1000
C	43				43			43		43			43				43
Art. 665	Tipo / Type T.2				Tipo / Type T.2			Tipo / Type T.2		Tipo / Type T.2			Tipo / Type T.2				Tipo / Type T.3
P	300				200	250	300x2	250	200x2	300x2			200x2	300x2			400x2
kg	42				29	41	59	41	42	59			42	59			81,5
Cod.	9.81.P2060S2	9.81.P2040S2	9.81.P2060S2	9.81.P2060S3	9.81.P2080S3	9.81.P2060S2	9.81.P2060S3	9.81.P2060S2	9.81.P2060S3	9.81.P2080S3	9.81.P2060S3	9.81.P2060S3	9.81.P2060S3	9.81.P2080S3	9.81.P32580S3	9.81.P325100S3	



**GANASCE FISSE PER MORSE FMS**  
**FIXED JAWS FOR FMS VISES**

Tipo (grandezza) / Type (size)	1	2	3	4	5	6
<b>Art. 805*</b> Ganascia fissa zigrinata da un lato Fixed jaw one side serrated	Cod. 5.80.51000	5.80.52000	5.80.53000	5.80.54000	5.80.55000	5.80.56000
<b>Art. 805A*</b> Ganascia fissa liscia Smooth fixed jaw	Cod. 5.80.5A100	5.80.5A200	5.80.5A300	5.80.5A400	5.80.5A500	5.80.5A600
<b>Art. 805B*</b> Ganascia fissa dolce Soft fixed jaw	Cod. 5.80.5B100	5.80.5B200	5.80.5B300	5.80.5B400	5.80.5B500	5.80.5B600
<b>Art. 805C*</b> Ganascia fissa zigrinata da ambo i lati Fixed jaw serrated on both sides	Cod. 5.80.5C100	5.80.5C200	5.80.5C300	5.80.5C400	5.80.5C500	5.80.5C600
<b>Art. 870A*</b> Ganascia fissa intermedia alta Fixed Intermediate high jaw	Cod. 5.87.0A100	5.87.0A200	5.87.0A300	5.87.0A400	5.87.0A500	5.87.0A600

**Art. 805** (Montata su Art. 860)  
(Assembled on Art. 860)

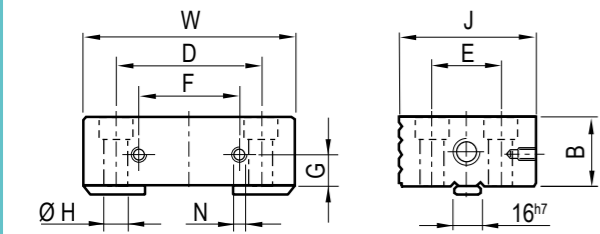

**Art. 805N** (Montata su Art. 863)  
(Assembled on Art. 863)

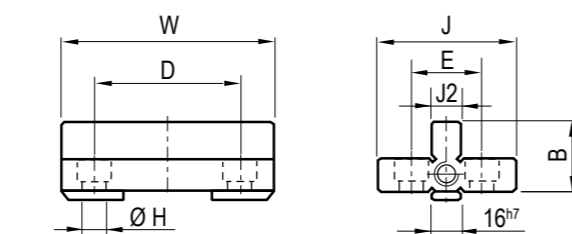

**Art. 805O** Ganascia fissa con gradino piccolo e grande  
Fixed jaw with small and large step

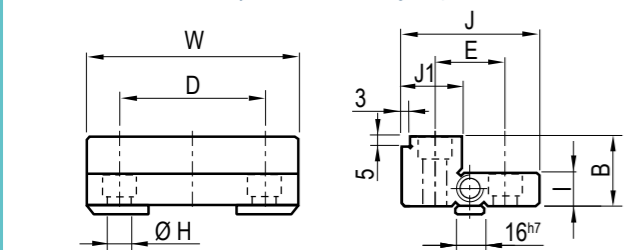

**Art. 805F** (Montata su Art. 866)  
(Assembled on Art. 866)

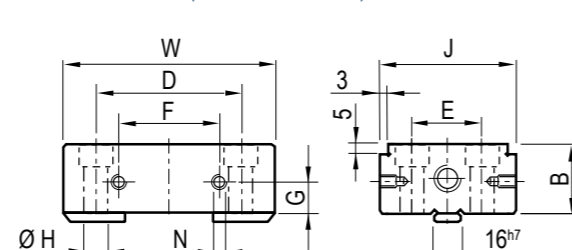

Tipo (grandezza) morsa / Vise (type) size

mm	1	2	3	4	5	6	Tolleranze Tolerance
W	74	94	124	144	169	189	-
J	56	64	84	98	108	108	- 0,02
J1	24	24	30	38	38	38	
J2	16	16	16	16	16	16	
B	25	30	40	50	60	60	- 0,02
D	56	70	92	108	126	144	-
E	32	40	50	60	68	68	-
F	40	50	65	65	65	100	-
G	10	10	15	20	25	25	-
H	9	11	13	17	17	22	-
I	12,5	15	20	25	30	30	- 0,02
N	M5	M6	M6	M6	M6	M6	-

\* Set viti per fissaggio a richiesta - Fixing screws set on request

Tipo (grandezza) / Type (size)	1	2	3	4	5	6
<b>Art. 805D*</b> Ganascia fissa con gradino 3x5 zigrinata da un lato Fixed jaw with 3x5 step on side serrated	Cod. 5.80.5D100	5.80.5D200	5.80.5D300	5.80.5D400	5.80.5D500	5.80.5D600
<b>Art. 805E*</b> Ganascia fissa con gradino 3x5 liscia Fixed jaw with 3x5 step smooth	Cod. 5.80.5E100	5.80.5E200	5.80.5E300	5.80.5E400	5.80.5E500	5.80.5E600
<b>Art. 805F*</b> Ganascia fissa con doppio gradino 3x5 liscia Fixed jaw with double 3x5 step smooth	Cod. 5.80.5F100	5.80.5F200	5.80.5F300	5.80.5F400	5.80.5F500	5.80.5F600
<b>Art. 805G*</b> Ganascia fissa con doppio gradino 3x5 zigrinata Fixed jaw with double 3x5 step serrated	Cod. 5.80.5G100	5.80.5G200	5.80.5G300	5.80.5G400	5.80.5G500	5.80.5G600
<b>Art. 805H*</b> Ganascia fissa con prisma verticale Fixed jaw with vertical prism	Cod. 5.80.5H100	5.80.5H200	5.80.5H300	5.80.5H400	5.80.5H500	5.80.5H600
<b>Art. 805I*</b> Ganascia fissa con doppio prisma verticale Fixed jaw with double vertical prism	Cod. 5.80.5I100	5.80.5I200	5.80.5I300	5.80.5I400	5.80.5I500	5.80.5I600
<b>Art. 805J*</b> Ganascia fissa con prisma orizzontale Fixed jaw with horizontal prism	Cod. 5.80.5J100	5.80.5J200	5.80.5J300	5.80.5J400	5.80.5J500	5.80.5J600
<b>Art. 805K*</b> Ganascia fissa con doppio prisma orizzontale Fixed jaw with double horizontal prism	Cod. 5.80.5K100	5.80.5K200	5.80.5K300	5.80.5K400	5.80.5K500	5.80.5K600
<b>Art. 805L*</b> Ganascia fissa con gradino Step fixed jaw	Cod. 5.80.5L100	5.80.5L200	5.80.5L300	5.80.5L400	5.80.5L500	5.80.5L600
<b>Art. 805M*</b> Ganascia fissa con gradino zigrinata da un lato Step fixed jaw one side serrated	Cod. 5.80.5M100	5.80.5M200	5.80.5M300	5.80.5M400	5.80.5M500	5.80.5M600
<b>Art. 805N*</b> Ganascia fissa con doppio gradino Fixed jaw with double step	Cod. 5.80.5N100	5.80.5N200	5.80.5N300	5.80.5N400	5.80.5N500	5.80.5N600
<b>Art. 805O*</b> Ganascia fissa con gradino piccolo e grande liscia da un lato Fixed jaw with small and large step on side smooth	Cod. 5.80.5O100	5.80.5O200	5.80.5O300	5.80.5O400	5.80.5O500	5.80.5O600
<b>Art. 805P*</b> Ganascia fissa con gradino piccolo e grande zigrin. da un lato Fixed jaw with small and large step one side serrated	Cod. 5.80.5P100	5.80.5P200	5.80.5P300	5.80.5P400	5.80.5P500	5.80.5P600
<b>Art. 805Q*</b> Ganascia fissa doppia con gradino piccolo e grande Double fixed jaw with small and large step	Cod. 5.80.5Q100	5.80.5Q200	5.80.5Q300	5.80.5Q400	5.80.5Q500	5.80.5Q600
<b>Art. 805R*</b> Ganascia fissa in alluminio Fixed jaw aluminium	Cod. 5.80.5R100	5.80.5R200	5.80.5R300	5.80.5R400	5.80.5R500	5.80.5R600
<b>Art. 805T*</b> Ganascia fissa doppia GRIP per forti serraggi GRIP Double fixed jaw for strongest clamping	Cod. 5.80.5T100	5.80.5T200	5.80.5T300	5.80.5T400	5.80.5T500	5.80.5T600
<b>Art. 805DT*</b> Ganascia fissa a coda di rondine Dove tail fixed jaw	Cod. 5.80.5DT10	5.80.5DT20	5.80.5DT30	5.80.5DT40	5.80.5DT50	5.80.5DT60

\* Set viti per fissaggio a richiesta - Set of fixing screws on request

Richiedere scheda tecnica - Technical data sheet on request

**GANASCE MOBILI PER MORSE FMS**  
**MOVABLE JAWS FOR FMS VISES**

Tipo (grandezza) / Type (size)	1	2	3	4	5	6
<b>Art. 810*</b> Ganascia mobile zigrinata da un lato Movable jaw one side serrated	Cod. 5.81.01000	5.81.02000	5.81.03000	5.81.04000	5.81.05000	5.81.06000
<b>Art. 810A*</b> Ganascia mobile liscia Smooth movable jaw	Cod. 5.81.0A100	5.81.0A200	5.81.0A300	5.81.0A400	5.81.0A500	5.81.0A600
<b>Art. 810B*</b> Ganascia mobile dolce Soft movable jaw	Cod. 5.81.0B100	5.81.0B200	5.81.0B300	5.81.0B400	5.81.0B500	5.81.0B600
<b>Art. 810D*</b> Ganascia mobile con gradino 3x5 zigrinata da un lato Movable jaw with 3x5 step on side serrated	Cod. 5.81.0D100	5.81.0D200	5.81.0D300	5.81.0D400	5.81.0D500	5.81.0D600
<b>Art. 814*</b> Base mobile per ganasce fisse Movable base for fixed jaws	Cod. 5.81.41000	5.81.42000	5.81.43000	5.81.44000	5.81.45000	5.81.4.6000

Predisposizione per tutte le ganasce FMS fisse - Fit all FMS fixed jaws

**Art. 810** (Montata su Art. 860) / (Assembled on Art. 860)

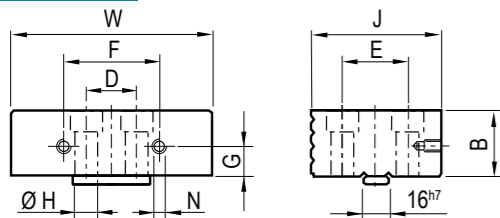

**Art. 810J** (Montata su Art. 870) / (Assembled on Art. 870)

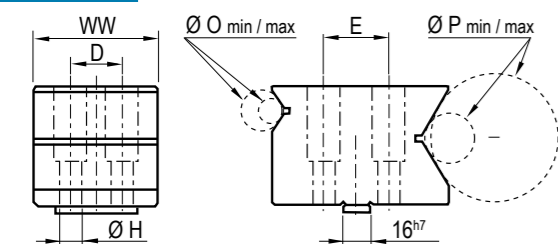

**Art. 810O** Ganascia mobile con gradino piccolo e grande  
Movable jaw with small and large step

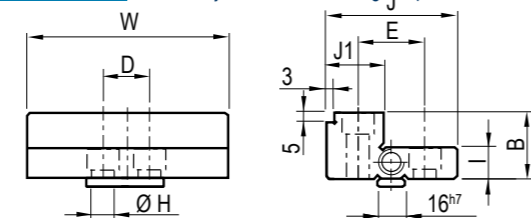

**Art. 814** Base mobile per ganasce fisse - Movable base for fixed jaws

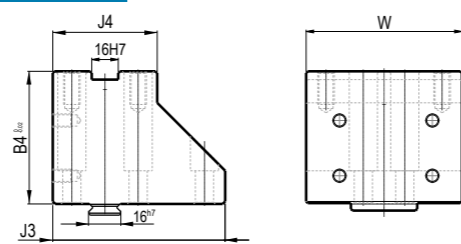

Tipo / Type	1x200	1x300	2	3	4	5	6	Tolleranze Tolerance
W	74		94	124	144	169	189	-
WW	60		75	100	132	140	160	-
B	25		30	40	50	60	60	-0,02
B4	60		80	90	110	120	160	-0,02
D	20		25	38	44	44	54	-
E	26	32	40	50	60	68	68	-
F	40		50	65	65	65	100	-
G	10		10	15	20	25	25	-
H	9		11	13	17	17	22	-
I	12,5		15	20	25	30	30	-0,02
J	56		64	84	98	108	108	-0,02
J1	24		24	30	38	38	38	-0,02
J3	76	76	104	134	158	169	189	-
J4	55		63	83	97	106	107	-
N	M5		M6	M6	M6	M6	M6	-
Ø O	10 / 15		20 / 30	25 / 30	20 / 60	35 / 70	40 / 80	-
Ø P	10 / 25		20 / 50	40 / 100	45 / 150	63 / 200	73 / 300	-

\* Set viti per fissaggio a richiesta - Fixing screws set on request

Tipo (grandezza) / Type (size)	1	2	3	4	5	6
<b>Art. 810E*</b> Ganascia mobile con gradino 3x5 liscia Movable jaw with 3x5 step smooth	Cod. 5.81.0E100	5.81.0E200	5.81.0E300	5.81.0E400	5.81.0E500	5.81.0E600
<b>Art. 810J*</b> Ganascia mobile prismatica per tondi liscia Prismatic movable jaw for round parts smooth	Cod. 5.81.0J100	5.81.0J200	5.81.0J300	5.81.0J400	5.81.0J500	5.81.0J600
<b>Art. 810K*</b> Ganascia mobile prismatica per tondi zigrinata Prismatic movable jaw for round parts serrated	Cod. 5.81.0K100	5.81.0K200	5.81.0K300	5.81.0K400	5.81.0K500	5.81.0K600
<b>Art. 810L*</b> Ganascia mobile con gradino Step movable jaw	Cod. 5.81.0L100	5.81.0L200	5.81.0L300	5.81.0L400	5.81.0L500	5.81.0L600
<b>Art. 810M*</b> Ganascia mobile con gradino zigrinata da un lato Step movable jaw one side serrated	Cod. 5.81.0M100	5.81.0M200	5.81.0M300	5.81.0M400	5.81.0M500	5.81.0M600
<b>Art. 810O*</b> Ganascia mobile con gradino piccolo e grande Movable jaw with small and large step	Cod. 5.81.0O100	5.81.0O200	5.81.0O300	5.81.0O400	5.81.0O500	5.81.0O600
<b>Art. 810P*</b> Ganascia mobile con gradino piccolo e grande zigrin. da un lato Movable jaw with small and large step one side serrated	Cod. 5.81.0P100	5.81.0P200	5.81.0P300	5.81.0P400	5.81.0P500	5.81.0P600
<b>Art. 810R*</b> Ganascia mobile in alluminio Movable jaw aluminium	Cod. 5.81.0R100	5.81.0R200	5.81.0R300	5.81.0R400	5.81.0R500	5.81.0R600
<b>Art. 810T*</b> Ganascia mobile GRIP per forti serraggi GRIP movable jaw for strongest clamping	Cod. 5.81.0T100	5.81.0T200	5.81.0T300	5.81.0T400	5.81.0T500	5.81.0T600
<b>Art. 810DT</b> Ganascia mobile a coda di rondine Dove tail movable jaw	Cod. 5.81.0DT10	5.81.0DT20	5.81.0DT30	5.81.0DT40	5.81.0DT50	5.81.0DT60
<b>Art. 810V*</b> Ganascia mobile con segmenti oscillanti Movable jaw with floating inserts	Cod. 5.81.0V100	5.81.0V200	5.81.0V300	5.81.0V400	5.81.0V500	5.81.0V600
<b>Art. 512*</b> Ganascia intermedia Intermediate Jaw	Cod. 5.51.21000	5.51.22000	5.51.23000	5.51.24000	5.51.25000	5.51.26000

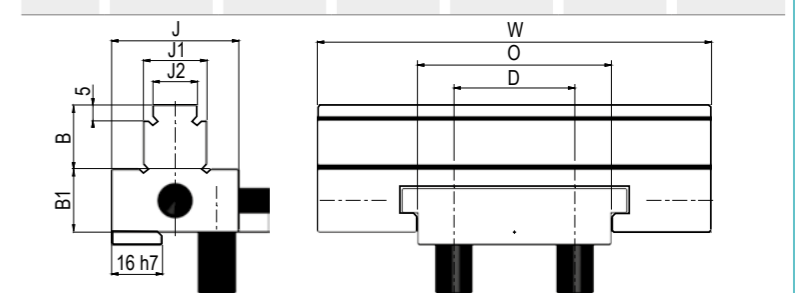
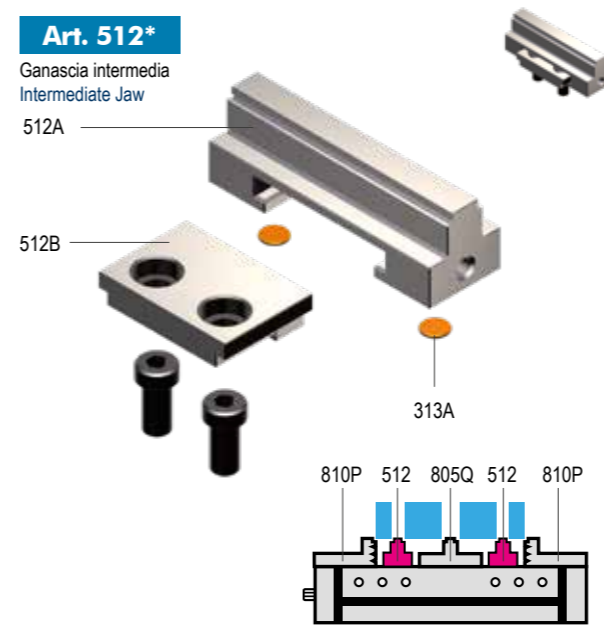

Type	1	2	3	4	5	6
W	74	94	124	144	169	189
J	25	35	40	40	50	50
J1	15	15	20	20	30	30
J2	9	9	14	14	19	19
B / B1	12,5	15	20	25	30	30
D	20	25	38	44	44	54
O	34	40	60	70	81	93

\* Set viti per fissaggio a richiesta - Set of fixing screws on request

## PIASTRE GANASCE PIANE CON INSERTI GRIP STRAIGHT INSERT GRIP JAW PLATES

**NEW**  
**22/23**

**Art. 547G** Piastra Piana con inserti GRIP  
Straight plate with GRIP inserts

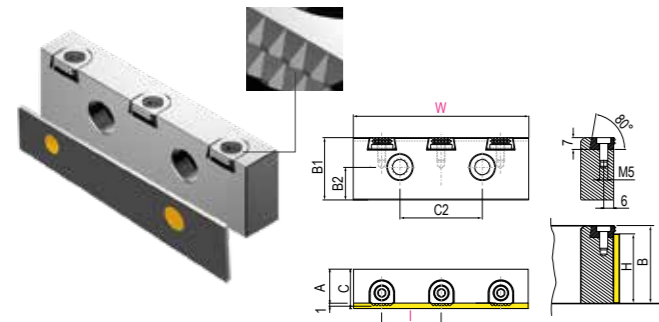

**Dotazione Standard - Standard Equipment**  
1 pc. Art.414R parallela magnetica - 1 pc. Art.414R magnetic parallel

Type	1	2	3	4	5	6
W	74	94	124	144	169	189
I	26	33	23,5	29,5	23	27
C	22,7	22,7	22,7	22,7	22,7	22,7
C2	40	50	65	65	65	100
B	25	30	40	50	60	60
B1	25	30	40	50	60	60
B2	10	10	15	20	25	25
A	20	20	20	20	20	20
H	20	25	35	45	55	55
Cod.	5.54.7G100	5.54.7G200	5.54.7G300	5.54.7G400	5.54.7G500	5.54.7G600

**Art. 547K** Piastra Piana a gradino integrale con inserti GRIP  
Straight integral step plate with GRIP inserts

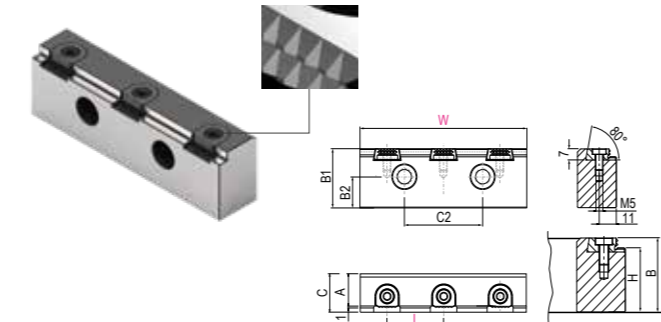

Type	1	2	3	4	5	6
W	74	94	124	144	169	189
I	26	33	23,5	29,5	23	27
C	25	25	25	25	25	25
C2	40	50	65	65	65	10
B	25	30	40	50	60	60
B1	25	30	40	50	60	60
B2	10	10	15	20	25	25
A	20	20	20	20	20	20
H	20	25	35	45	55	55
Cod.	5.54.7K100	5.54.7K200	5.54.7K300	5.54.7K400	5.54.7K500	5.54.7K600

## INSERTI GRIP PER MORSE FMS INSERT GRIP JAW PLATES FOR FMS VISES

**Art. 220 G01**

Per materiali di durezza normale  
For standard workpieces hardness clamping



Cod. 4.22.01000 / G01

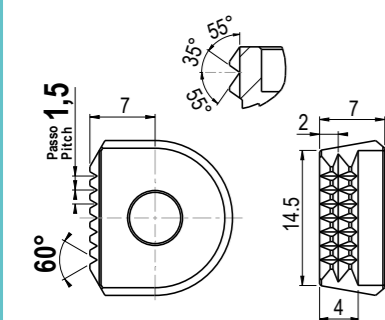

**Art. 220 G02**

Per materiali di notevole durezza.  
For hardened workpieces clamping



Cod. 4.22.01000 / G02

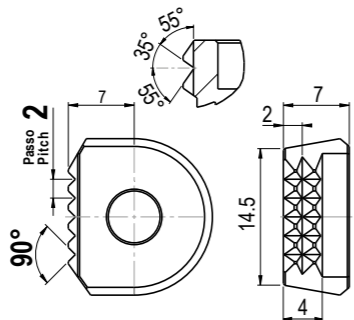

**Art. 220 G11**

Per materiali teneri  
For soft material clamping



Cod. 4.22.01000 / G11

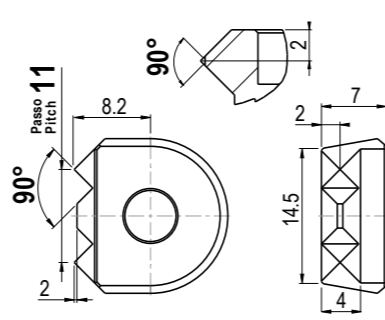

Tipo / Type	1	2	3	4	5	6
Art.547G - Art.547K	3 pcs each	3 pcs each	5 pcs each	5 pcs each	7 pcs each	7 pcs each
Viti a testa bassa M5 x 10mm Low head screws M5 x 10mm	3 pcs each	3 pcs each	5 pcs each	5 pcs each	7 pcs each	7 pcs each

## PIASTRE PER MORSE FMS PLATES FOR FMS VISES

Tipo (grandezza) / Type (size)

**Art. 823**

Piastra intermedia per Art. 855  
Middle plate for Art. 855



Cod. 5.82.31000 5.82.32000 5.82.33000 5.82.34000 5.82.35000 5.82.36000

**Art. 823B**

Piastra intermedia per Art. 800  
Middle plate for Art. 800

Cod. 5.82.3B100 5.82.3B200 5.82.3B300 5.82.3B400 5.82.3B500 5.82.3B600

**Art. 825**

Piastra di contenimento vite per morse FMS per Art. 855  
Screw holding plate for FMS vise for Art. 855

Cod. 5.82.51000 5.82.52000 5.82.53000 5.82.54000 5.82.55000 5.82.56000

**Art. 825B**

Piastra di contenimento vite per morse FMS per Art. 800  
Screw holding plate for FMS vise for Art. 800

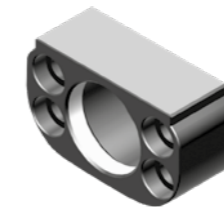

Cod. 5.82.5B100 5.82.5B200 5.82.5B300 5.82.5B400 5.82.5B500 5.82.5B600

**Art. 825C**

Piastra di contenimento vite per morse FMS per Art. 855W  
Screw holding plate for FMS vise for Art. 855W

Cod. 5.82.5C100 5.82.5C200 5.82.5C300 5.82.5C400 5.82.5C500 5.82.5C600

**Art. 831**

Piastra di collegamento per 2 morse FMS  
montate verticalmente dorso a dorso o fianco a fianco  
Connecting plate for 2 FMS vises  
vertically mounted back-to-back or side by side



Cod. 5.83.11000 5.83.12000 5.83.13000 5.83.14000 5.83.15000 5.83.16000

**Art. 832**

Piastra di collegamento per 4 morse FMS montate  
verticalmente dorso a dorso o fianco a fianco  
Connecting plate for 4 FMS vises  
vertically mounted back-to-back or side by side

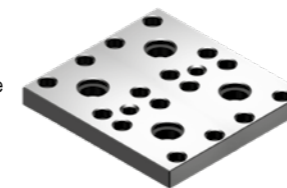

Cod. 5.83.21000 5.83.22000 5.83.23000 5.83.24000 5.83.25000 5.83.26000

**Art. 833**

Piastra di collegamento personalizzata per 2 morse FMS  
Connecting plate for 2 FMS vises tailor made

Cod. 5.83.31000 5.83.32000 5.83.33000 5.83.34000 5.83.35000 5.83.36000

**Art. 834**

Piastra di collegamento personalizzata per 4 morse FMS  
Connecting plate for 4 FMS vises tailor made

Cod. 5.83.41000 5.83.42000 5.83.43000 5.83.44000 5.83.45000 5.83.46000

**PIASTRE BASE PER MORSE FMS**  
**BASE PLATES FOR FMS VISES**

Tipo (grandezza) / Type (size)	1	2	3	4	5	6	7
--------------------------------	---	---	---	---	---	---	---

**Art. 827A**

Piastra base personalizzata per una o più morse  
 Bussola di centraggio Art. 852 compresa  
 Tailor made head plate for one or more vises  
 Centering bushing Art. 852 included

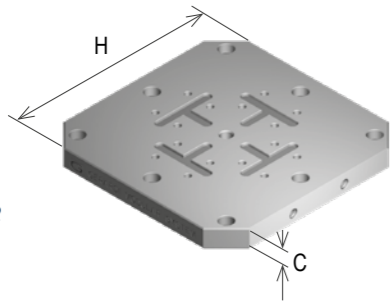

H	300	350	400	450	500	630	800
C	33	33	38	38	38	38	38
Kg	21,5	29,5	43,5	55	70	112	181
Cod.	5.82.7A100	5.82.7A200	5.82.7A300	5.82.7A400	5.82.7A500	5.82.7A600	5.82.7A700

**Art. 828A**

Piastra base personalizzata per cubo morsa bussola di centraggio Art. 852 compresa  
 Tailor made head plate for vise tower  
 Centering bushing Art. 852 included

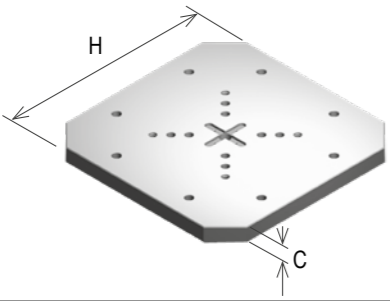

H	300	350	400	450	500	630	800
C	33	33	38	38	38	38	38
Kg	22	30	44,5	56,5	71	113	182
Cod.	5.82.8A100	5.82.8A200	5.82.8A300	5.82.8A400	5.82.8A500	5.82.8A600	5.82.8A700

Tipo (grandezza) / Type (size)	1	2	3	4	5	6
--------------------------------	---	---	---	---	---	---

**Art. 835**

Distanziale quadrato per 4 morse FMS  
 Square spacer for 4 FMS vises

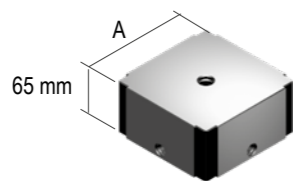

A	75	95	125	145	170	190
Cod.	5.83.51000	5.83.52000	5.83.53000	5.83.54000	5.83.55000	5.83.56000

**Art. 836**

Supporto quadrato per 4 morse FMS  
 Square support for 4 FMS vises

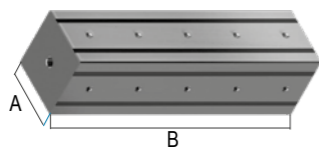

A	75	95	125	145	170	190
B	200	300	400	500	600	800
Cod.	5.83.61000	5.83.62000	5.83.63000	5.83.64000	5.83.65000	5.83.66000

**Art. 837**

Supporto esagonale per 6 morse FMS  
 Exagon support for 6 FMS vises

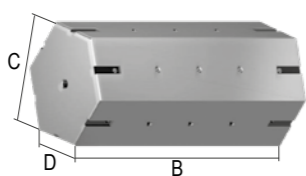

B	200	300	400	500	600	800
C	132	170	220	255	300	335
D	76 ~	98 ~	127 ~	147 ~	173 ~	193 ~
Cod.	5.83.71000	5.83.72000	5.83.73000	5.83.74000	5.83.75000	5.83.76000

**Art. 838**

Distanziale esagonale per 6 morse FMS  
 Exagon spacer for 6 FMS vises

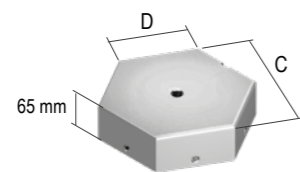

C	132	170	220	255	300	335
D	76 ~	98 ~	127 ~	147 ~	173 ~	193 ~
Cod.	5.83.81000	5.83.82000	5.83.83000	5.83.84000	5.83.85000	5.83.86000

**Art. 852**

Bussola di centraggio per piastra base  
 Centering bushing for base plate

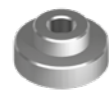

Cod.	5.85.21000	5.85.22000	5.85.23000	5.85.24000	5.85.25000	5.85.26000
------	------------	------------	------------	------------	------------	------------

**Art. 853**

Centraggio orizzontale per cubo FMS  
 Horizontal centering for FMS cube



Cod.	5.85.31000	5.85.32000	5.85.33000	5.85.34000	5.85.35000	5.85.36000
------	------------	------------	------------	------------	------------	------------

Tipo (grandezza) / Type (size)	1	2	3	4	5	6
--------------------------------	---	---	---	---	---	---

**Art. 825A**

Ghiera per morse e cubi FMS  
 Nut for FMS vises and cubes



Cod.	5.82.5A100	5.82.5A200	5.82.5A300	5.82.5A400	5.82.5A500	5.82.5A600
------	------------	------------	------------	------------	------------	------------

**Art. 850B**

Riparo lato vite  
 Protection side screw



Cod.	5.85.0B100	5.85.0B200	5.85.0B300	5.85.0B400	5.85.0B500	5.85.0B600
------	------------	------------	------------	------------	------------	------------

**Art. 850C**

Riparo  
 Protection

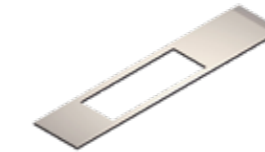

Cod.	5.85.0C100	5.85.0C200	5.85.0C300	5.85.0C400	5.85.0C500	5.85.0C600
------	------------	------------	------------	------------	------------	------------

**Art. 850P**

Dispositivo "Terza Mano"  
 "Third Hand" device

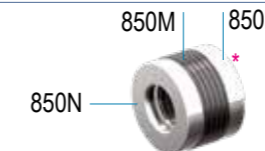

Cod.	5.85.0P100	5.85.0P200	5.85.0P300	5.85.0P400	5.85.0P500	5.85.0P600
------	------------	------------	------------	------------	------------	------------

Foto indicativa  
 Indicative picture

**Art. 850E**

Bussola esagonale per innesto automatico  
 Hexagonal bushing for automatic connection

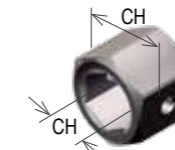

CH	12 / 22	14 / 24	19 / 30	19 / 30	27 / 40	27 / 40
Cod.	5.85.0E100	5.85.0E200	5.85.0E300	5.85.0E400	5.85.0E500	5.85.0E600

**Art. 850T**

Distanziale per morsa solo autocentrante  
 Spacer for Self-centering vise only



Cod.	5.85.0T100	5.85.0T200	5.85.0T300	5.85.0T400	5.85.0T500	5.85.0T600
------	------------	------------	------------	------------	------------	------------

**Art. 850H**

Chiave esagonale per morsa FMS e cubo  
 Hexagonal wrench for FMS vise and cube



Cod.	5.85.0H100	5.85.0H300	5.85.0H500
------	------------	------------	------------

**Art. 801S**

Piastrina di collegamento slitte morsa  
 Slides vise connecting plate



Cod.	5.80.1S100	5.80.1S200	5.80.1S300	5.80.1S400	5.80.1S500	5.80.1S600
------	------------	------------	------------	------------	------------	------------

**Dimensioni / Dimension**
**Art.375**

Chiave a pipa  
 Box wrench

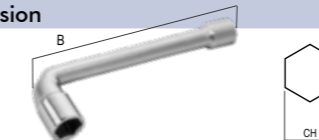

	CH	B	CH	B	CH	B	CH	B	CH	B	CH	B
	16	250	16	250	19	250	19	250	19	250	19	250
Cod.	4.37.516250	4.37.516250	4.37.519250	4.37.519250	4.37.519250	4.37.519250	4.37.519250	4.37.519250	4.37.519250	4.37.519250	4.37.519250	4.37.519250

**RICAMBI PER MORSE Art.800 - SPARE PARTS FOR VISES Art.800**
**Art. 800E**

Guarnizione per slitta integrale  
 O ring for solid slide



Cod.	5.80.0E100	5.80.0E200	5.80.0E300	5.80.0E400	5.80.0E500	5.80.0E600
------	------------	------------	------------	------------	------------	------------

**Art. 801G**

Grano di bloccaggio protezione centrale  
 Setscrew for clamping central protection



Cod.	5.80.1G100	5.80.1G200	5.80.1G300	5.80.1G400	5.80.1G500	5.80.1G600
------	------------	------------	------------	------------	------------	------------

**Art. 800I**

Vite tcei per ganasce  
 Hex.socket head screw for jaws



Cod.	5.80.0I100	5.80.0I200	5.80.0I300	5.80.0I400	5.80.0I500	5.80.0I600
------	------------	------------	------------	------------	------------	------------

**Art. 801H**

Vite tcei per ganasce a gradino  
 Hex.socket head screw for step jaws



Cod.	5.80.1H100	5.80.1H200	5.80.1H300	5.80.1H400	5.80.1H500	5.80.1H600
------	------------	------------	------------	------------	------------	------------

Cod.	5.80.1I100	5.80.1I200	5.80.1I300	5.80.1I400	5.80.1I500	5.80.1I600
------	------------	------------	------------	------------	------------	------------

**Art. 801I**

Vite tcei per piastra di contenimento  
 Hex.socket head screw for screw holding plate



Cod.	5.80.1I100	5.80.1I200	5.80.1I300	5.80.1I400	5.80.1I500	5.80.1I600
------	------------	------------	------------	------------	------------	------------

**SERVOCOMANDI OLEODINAMICI PER MOTORI IDRAULICI**  
**ELECTRO-HYDRAULIC POWER PACK FOR HYDRAULIC MOTORS**

Tipo (grandezza) / Type (size)	1	2	3	4	5	6
<b>Art. 566</b> Motore idraulico / Hydraulic motor	OMM32	OMP80	OMR200	OMR200	OMR200	OMR200
bar	140					
A mm	75	130	123	145	168	188
B mm	70	100	104	119	139	159
C mm	175	234	244	246	261	261
Cod.	5.89.01000	5.89.02000	5.89.03000	5.89.04000	5.89.05000	5.89.06000

**Art.890**

**Art. 566 + Art. 571 + Art. 891 + Art. 892**

Motore idraulico completo di piastra d'interfaccia, boccola e fine corsa elettronico regolabile  
Hydraulic motor complete with connecting plate, bushing and adjustable electronic proximity switch

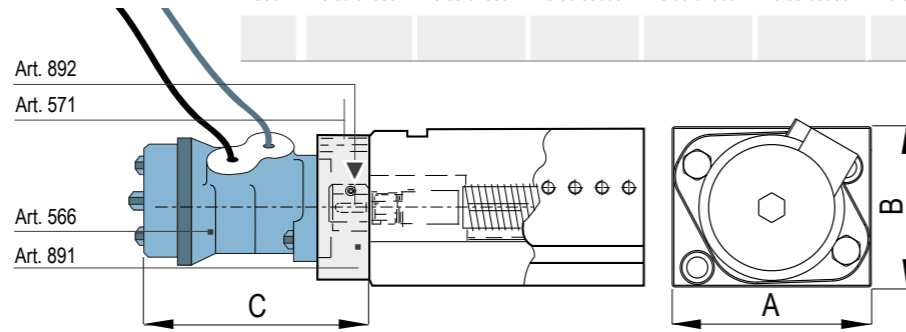

<b>Art. 891</b> Piastra attacco motore idraulico / Hydraulic motor mounting plate	Cod.	5.89.11000	5.89.12000	5.89.13000	5.89.14000	5.89.15000	5.89.16000
<b>Art. 892</b> Boccola di trascinamento vite motore / Drive bushing screw-motor	Cod.	5.89.21000	5.89.22000	5.89.23000	5.89.24000	5.89.25000	5.89.26000
<b>Art. 566</b> Motore Idraulico / Hydraulic motor	Cod.	5.56.61000	5.56.62000	5.56.63000	5.56.63000	5.56.63000	5.56.63000
<b>Art. 571</b> Fine corsa elettronico / Electronic proximity switch	Cod.	5.57.11000	5.57.12000	5.57.13000	5.57.14000	5.57.15000	5.57.16000

Tipo (grandezza) / Type (size)	1	2	3	4	5	6
<b>Art.890K/1</b>	2	2	2	2	3	3
Passo vite / screw pitch mm	2	2	2	2	3	3
bar	130	100	100	100	120	120
l/min	5	10	20	20	20	20
Cod.	5.89.0K101	5.89.0K201	5.89.0K301	5.89.0K401	5.89.0K501	5.89.0K601

**Art. 266B + Art. 890**

Kit per automazione morse FMS  
Kit for FMS vises automation.

**DATI TECNICI:**  
IDROMOTORE: Art.566  
Motore elettrico Kw 5,5  
Portata Min. 40 litri al minuto  
Velocità apertura-chiusura morse da calcolarsi in base al diagramma idromotore (vedi pag. 5.65)  
Per il diagramma forza di serraggio vedi pag. 5.74  
Pressione massima di esercizio: 140 bar

**TECHNICAL DATA:**  
HYDRAULIC MOTOR Art.566  
Electric motor kW 5,5  
Oil pumps: 40l/min  
Opening and closing speed of vise to be calculated from hydraulic motor diagram at page 5.65  
**For clamping forces diagram see pag. 5.75**  
**Max operating pressure: 140 bar**

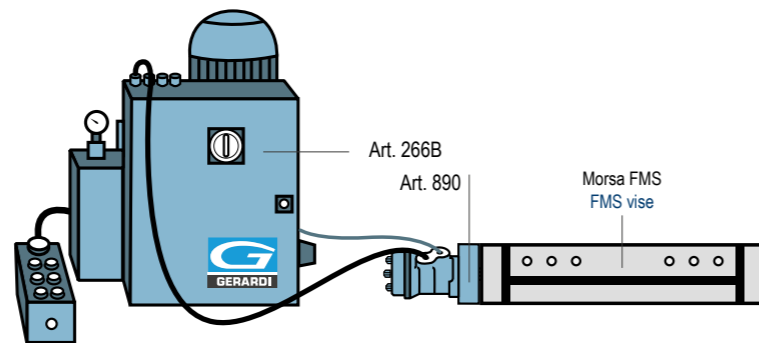

- COMPOSIZIONE COMPLETA DI:**
- N° 1 servocomando Art. 890
  - N° 1 centralina elettroidraulica Art. 266B/1
  - Comando manuale elettrico da pulsantiera con chiusura ed apertura indipendente, singola o simultanea
  - Regolazione forza di bloccaggio desiderata
  - Fine corsa elettronico regolabile
- COMPOSIZIONE COMPLETE OF:**
- N° 1 hydraulic servo unit Art. 890
  - N° 1 electro-hydraulic power pack Art. 266B/1
  - Electrically controlled by manual switch board
  - Adjustable clamping force as required
  - Adjustable electronic proximity switch

Tubi e cavi di collegamento elettrici ed idraulici con massima lunghezza 1600 mm / Hydraulic pipes and electrical cables with max length 1600 mm

**SERVOCOMANDI OLEODINAMICI PER MOTORI IDRAULICI**  
**ELECTRO-HYDRAULIC POWER PACK FOR HYDRAULIC MOTORS**

Tipo (grandezza) / Type (size)	1	2	3	4	5	6
<b>Art.890K/2</b>	2	2	2	2	3	3
Passo vite / screw pitch mm	2	2	2	2	3	3
bar	130	100	100	100	120	120
l/min	10	20	40	40	40	40
Cod.	5.89.0K102	5.89.0K202	5.89.0K302	5.89.0K402	5.89.0K502	5.89.0K602

**Art. 266B + 2 Art. 890**

Kit per automazione morse FMS  
Kit for FMS vises automation.

**DATI TECNICI:**  
IDROMOTORE: Art.566  
Motore elettrico Kw 5,5  
Portata Min. 40 litri al minuto  
Velocità apertura-chiusura morse da calcolarsi in base al diagramma idromotore (vedi pag. 5.65)  
Per il diagramma forza di serraggio vedi pag. 5.74  
Pressione massima di esercizio: 140 bar

**TECHNICAL DATA:**  
HYDRAULIC MOTOR Art.566  
Electric motor kW 5,5  
Oil pumps: 40l/min  
Opening and closing speed of vise to be calculated from hydraulic motor diagram at page 5.65  
**For clamping forces diagram see pag. 5.75**  
**Max operating pressure: 140 bar**

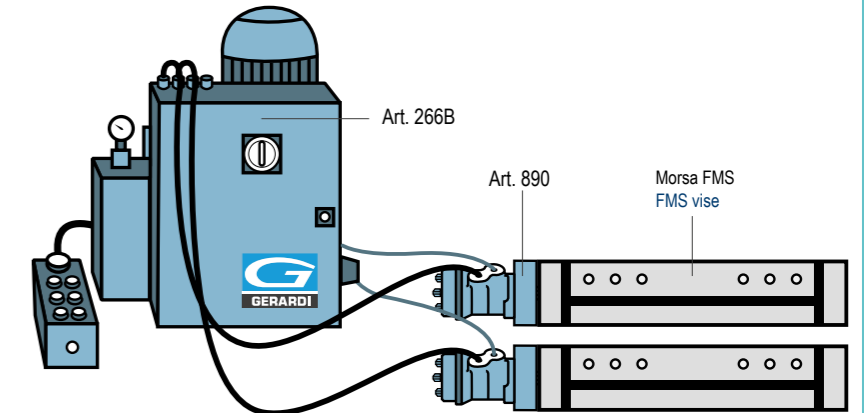

- COMPOSIZIONE COMPLETA DI:**
- N° 2 servocomandi Art. 89
  - N° 1 centralina elettroidraulica Art. 266B/1
  - Comando manuale elettrico da pulsantiera con chiusura ed apertura indipendente, singola o simultanea
  - Regolazione forza di bloccaggio desiderata
  - Fine corsa elettronico regolabile
- COMPOSIZIONE COMPLETE OF:**
- N° 2 hydraulic servo units Art. 890
  - N° 1 electro-hydraulic power pack Art. 266B/1
  - Electrically controlled by manual switch board
  - Adjustable clamping force as required
  - Adjustable electronic proximity switch

Tubi e cavi di collegamento elettrici ed idraulici con massima lunghezza 1600 mm / Hydraulic pipes and electrical cables with max length 1600 mm

Tipo (grandezza) / Type (size)	1	2	3	4	5	6
<b>Art.890K/3</b>	2	2	2	2	3	3
Passo vite / screw pitch mm	2	2	2	2	3	3
bar	130	100	100	100	120	120
l/min	15	30	60	60	60	60
Cod.	5.89.0K103	5.89.0K203	5.89.0K303	5.89.0K403	5.89.0K503	5.89.0K603

**Art. 266B + 3 Art. 890**

Kit per automazione morse FMS  
Kit for FMS vises automation.

**DATI TECNICI:**  
IDROMOTORE: Art.566  
Motore elettrico Kw 5,5  
Portata Min. 40 litri al minuto  
Velocità apertura-chiusura morse da calcolarsi in base al diagramma idromotore (vedi pag. 5.65)  
Per il diagramma forza di serraggio vedi pag. 5.74  
Pressione massima di esercizio: 140 bar

**TECHNICAL DATA:**  
HYDRAULIC MOTOR Art.566  
Electric motor kW 5,5  
Oil pumps: 40l/min  
Opening and closing speed of vise to be calculated from hydraulic motor diagram at page 5.65  
**For clamping forces diagram see pag. 5.75**  
**Max operating pressure: 140 bar**

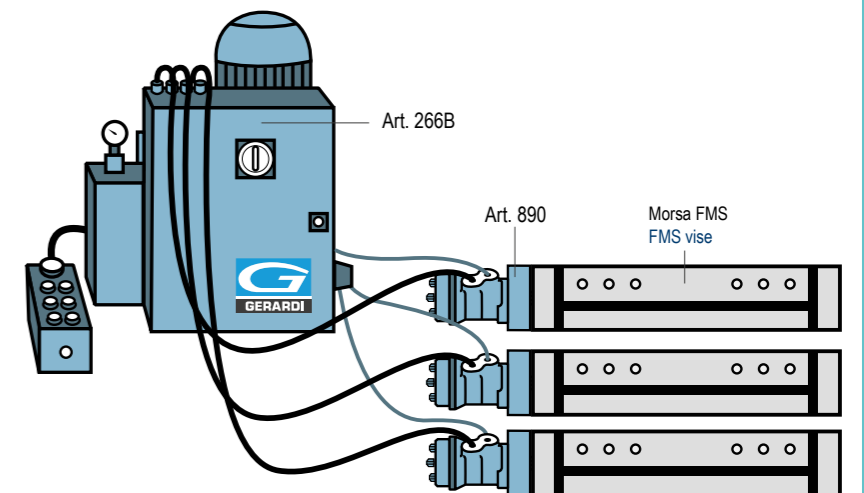

- COMPOSIZIONE COMPLETA DI:**
- N° 3 servocomandi Art. 89
  - N° 1 centralina elettroidraulica Art. 266B/1
  - Comando manuale elettrico da pulsantiera con chiusura ed apertura indipendente, singola o simultanea
  - Regolazione forza di bloccaggio desiderata
  - Fine corsa elettronico regolabile
- COMPOSIZIONE COMPLETE OF:**
- N° 3 hydraulic servo units Art. 890
  - N° 1 electro-hydraulic power pack Art. 266B/1
  - Electrically controlled by manual switch board
  - Adjustable clamping force as required
  - Adjustable electronic proximity switch

Tubi e cavi di collegamento elettrici ed idraulici con massima lunghezza 1600 mm / Hydraulic pipes and electrical cables with max length 1600 mm



**SERVOCOMANDI OLEODINAMICI PER MOTORI IDRAULICI**  
**ELECTRO-HYDRAULIC POWER PACK FOR HYDRAULIC MOTORS**

Tipo (grandezza) / Type (size)	1	2	3	4	5	6
Passo vite / screw pitch mm	2	2	2	2	3	3
bar	130	100	100	100	120	120
l/min	20	40	80	80	80	80
Cod.	5.89.0K104	5.89.0K204	5.89.0K304	5.89.0K404	5.89.0K504	5.89.0K604

**Art.890K/4**

Art. 266B + 4 Art. 890

Kit per automazione morse FMS  
Kit for FMS vises automation.

DATI TECNICI:  
IDROMOTORE: Art.566  
Motore elettrico Kw 5.5  
Portata Min. 40 litri al minuto  
Velocità apertura-chiusura morse da calcolarsi in base al digramma idromotore (vedi pag. 5.65)  
Per il diagramma forza di serraggio vedi pag. 5.74  
Pressione massima di esercizio: 140 bar

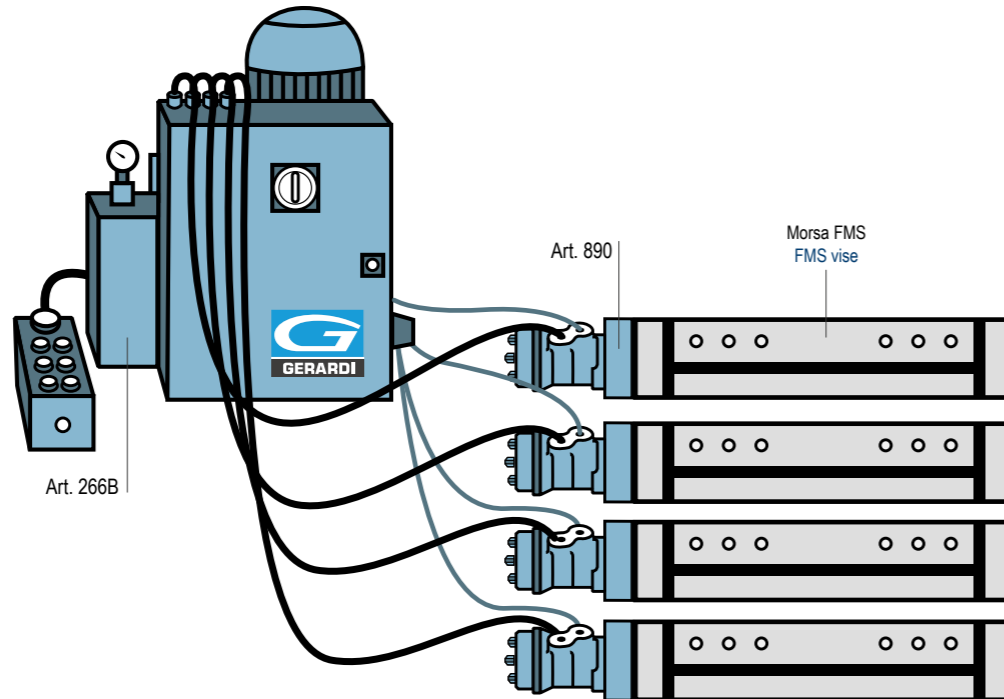

5 TECHNICAL DATA:  
HYDRAULIC MOTOR Art.566  
Electric motor kW 5,5  
Oil pumps: 40l/min  
Opening and closing speed of vise to be calculated from hydraulic motor diagram at page 5.65  
For clamping forces diagram see pag. 5.75  
Max operating pressure: 140 bar

- COMPOSIZIONE COMPLETA DI:
- N° 3 servocomandi Art. 89
  - N° 1 centralina elettroidraulica Art. 266B/1
  - Comando manuale elettrico da pulsantiera con chiusura ed apertura indipendente, singola o simultanea
  - Regolazione forza di bloccaggio desiderata
  - Fine corsa elettronico regolabile
- COMPOSITION COMPLETE OF:
- N° 3 hydraulic servo units Art. 890
  - N° 1 electro-hydraulic power pack Art. 266B/1
  - Electrically controlled by manual switch board
  - Adjustable clamping force as required
  - Adjustable electronic proximity switch

Riduttore epicicloidale il quale consente di moltiplicare notevolmente la coppia sviluppata dal motore idraulico consentendo di arrivare a elevate forze di serraggio, fino a 480 kN

Epicyclic force reducer able to multiply greatly the torque generated by the hydraulic engine reaching a very high clamping force, maximum 480kN.



Tubi e cavi di collegamento elettrici ed idraulici con massima lunghezza 1600 mm / Hydraulic pipes and electrical cables with max length 1600 mm

**DIAGRAMMI COPPIE MOTORI IDRAULICI**  
**HYDRAULIC MOTOR TORQUE DIAGRAMS**

**Art.890** (Art.890) Motore idraulico  
(Art.890) Hydraulic motor

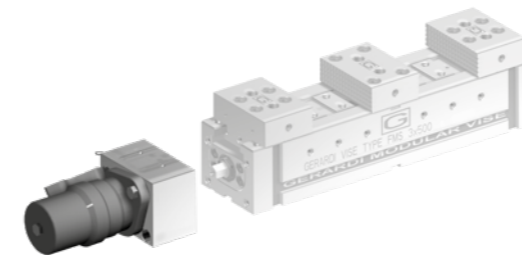

**OMR 32**  
Morse FMS tipo 1 / Type 1 FMS vises

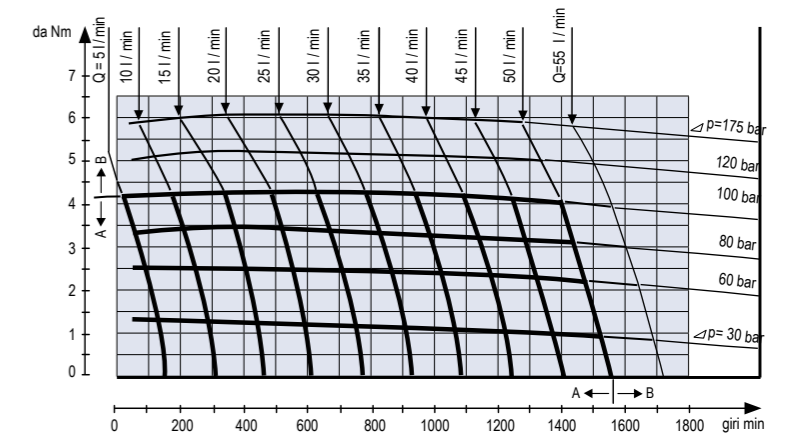

**Art.890** (Art.890) Motore idraulico  
(Art.890) Hydraulic motor

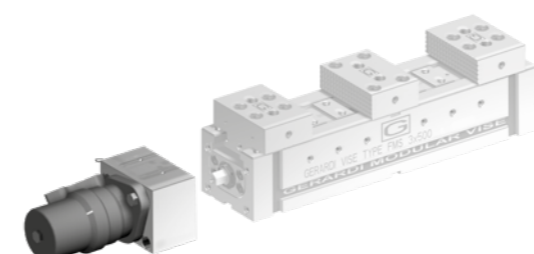

**OMR 80**  
Morse FMS tipo 2 / Type 2 FMS vises

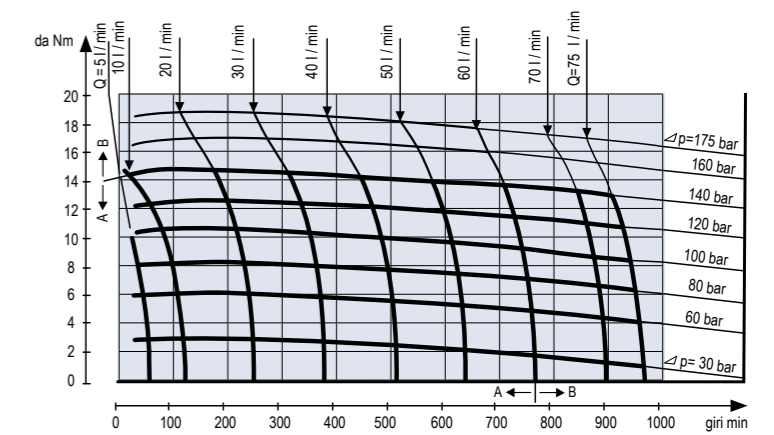

**Art.890** (Art.890) Motore idraulico  
(Art.890) Hydraulic motor

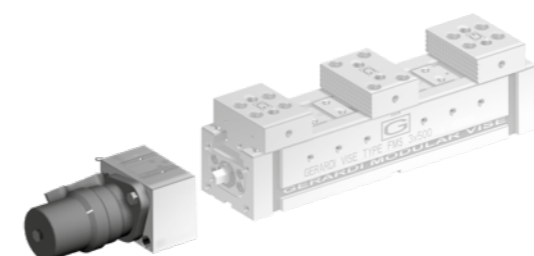

**OMR 200**  
Morse FMS tipo 3 - 4 - 5 - 6 Type 3 - 4 - 5 - 6 FMS vises

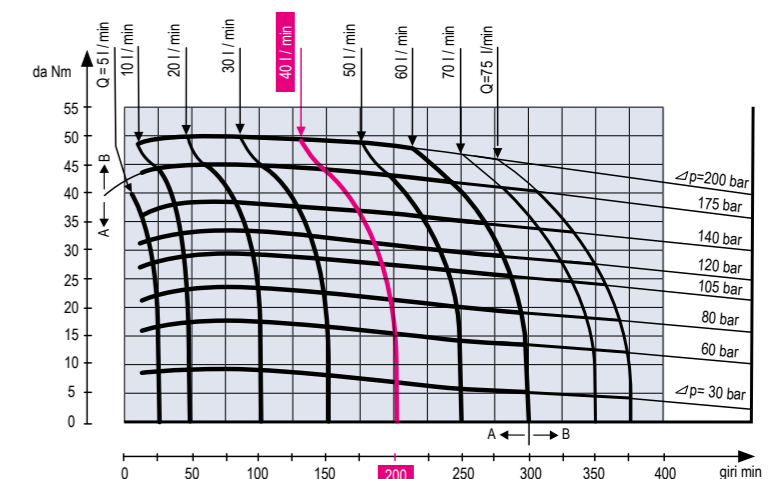

VELOCITA' = Passo vite x giri/min (dati dalla portata di olio in l/min) - 25% circa per attriti e resistenze varie.  
Esempio: Vite passo 2 mm; **Giri 200/min** (ipotizzando una portata olio di **40 l/min**);  $V = 2 \times 200 = 400 - 25\% = 300 \text{ mm/min}$  per una morse.  
Per più morse dividere la velocità ottenuta per il numero delle morse impiegate.

SPEED = Screw pitch x RPM (that you get from oil pump of 40 l/min) about - 25% for friction and other resistance.  
Example: Screw pitch 2mm; **RPM 200/min** (taking in consideration oil pump of **40 l/min**);  $V = 2 \times 200 = 400 - 25\% = 300 \text{ mm/min}$  for one vise.  
For more vises divide the speed obtained by the number of vises used.

# DIVISORE AUTOMATICO DPG 250

## AUTOMATIC DIVIDING HEAD DPG 250

Divisore automatico Automatic dividing head	Dati tecnici Technical Data	
--	--------------------------------	--

### DPG 250

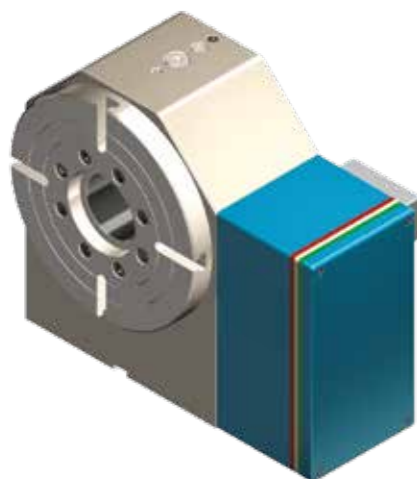

Diametro del divisore Dividing head diameter		250 mm
Diametro del foro passante Clearance hole diameter		70,5 mm
Altezza punta Center height		200 mm
Dimensione della scanalatura a T T-Slot width		12 mm
Sistema di bloccaggio Clamping system		IIdraulico Hydraulic
Forza frenante Clamping torque		3000 Nm
Motore Servo motor		3000 Max.g/min
Minimo incremento Minimum increment		0,002
Velocità di rotazione Rotation speed		33,3 Giri/min
Rapporti vite/corona Speed reduction ratio (screw/gear)		1/90
Rapporti vite/motore Speed reduction ratio (screw/motor)		1/180
Precisione Indexing accuracy		±10 Sec.
Ripetibilità Repeatability		4 Sec.
Max. carico di lavoro sul divisore Max. allowable work weight on the dividing head	Verticale Vertical	Kg.550
	Orizzontale Horizontal	Kg.1500
Max. carico di spinta applicabile sul divisore Max. allowable tool load on the dividing head		N 25000
		FxL Nm 1000
Rapporti vite/corona Speed reduction ratio (screw/gear)	Verticale Vertical	10,5 Kg. m <sup>2</sup>
	Corona dentata Worm gear	698 Nm
Kg		110
Cod.		8.DP.G2500

**PROGRAMMAZIONE TOUCH SCREEN**  
FACILE ED INTUITIVA O TRAMITE COLLEGAMENTO DIRETTO AL CNC

**EASY AND INTUITIVE TOUCH SCREEN PROGRAMMING OR THROUGH DIRECT CONNECTION TO THE CNC**

- Installazione semplice (alimentazione 220V)
- Corona in bronzo speciale
- Controsupporto semplice
- Vite senza fine in acciaio temprato e rettificato
- Vite e corona in bagno d'olio
- Cuscinetti a vite precaricati
- Cuscinetto anteriore a rulli incrociati sovradimensionato
- Recupero gioco con avvicinamento assiale
- Completa tenuta stagna ai liquidi con possibilità di pressurizzazione
- Possibilità di montare motori di tutte le marche
- Dimensioni esterne contenute
- Finestra di controlli liquidi e condensa
- Lavorazione in posizionamento a 360°
- Easy installation (220V)
- Special bronze crown
- Simple tailstock
- Worm screw in hardened ground steel
- Bath lubrication Screw and Crown
- Pre-loaded screw bearings
- Over-dimensioned crossed-roller front bearing
- Play recover with axial approach
- Watertight seal with possibility of pressurization
- Possibility to mount motors of all brands
- Reduced external dimensions
- Condensation and liquid control window
- 360° work positioning

### DPG 250

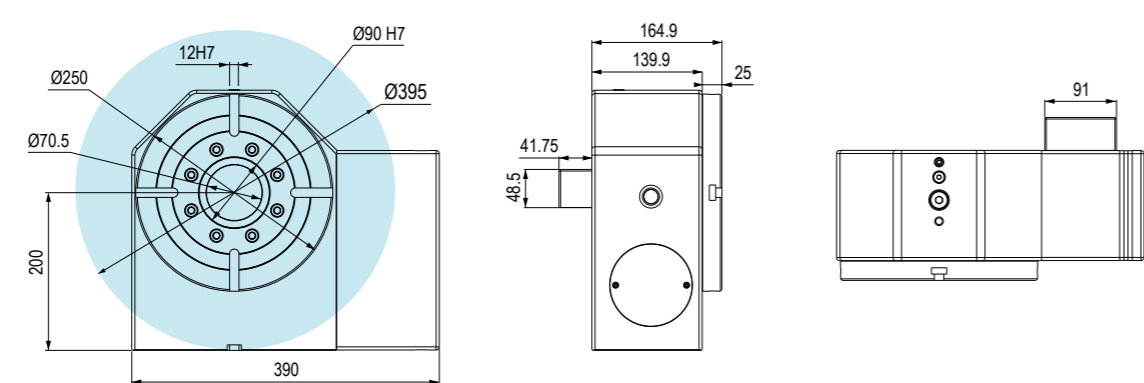

Tipo (grandezza) / Type (size)	1		2				3				
	25 kN		25 kN				30 kN				
	25 kN		25 kN				30 kN				
D	200	300	300	400	500	600	400	500	600	700	800
G1	120		175				210				
W	74		94				124				
Cod.	5.DP.G25000	5.DP.G25010	5.DP.G25020	5.DP.G25030	5.DP.G25040	5.DP.G25050	5.DP.G25060	5.DP.G25070	5.DP.G25080	5.DP.G25090	5.DP.G25011

Divisore Gerardi DPG250 con cubo-morsa FMS per serraggi singoli, doppi o autocentranti

Morse Art.860C Art.860C vises

3in1 VISES

Gerardi dividing head DPG250 with FMS vise-cube for single, double and self-centering clamping

Nel caso si disponga di un proprio divisore, il prezzo dell'attrezzatura potrebbe subire variazioni  
In case you already have a divider, the price may be revised

### UPGRADE YOUR VISE APPLICATIONS THROUGH MODULAR ACCESSORIES !

<b>Art. 99A</b>	Cod.	5.99.A1000				
Supporto Support						
<b>Art. 99B</b>	Cod.	5.99.B1000	5.99.B2000	5.99.B3000		
Perno di centraggio completo di sistema d'allineamento Horizontal centering pin with alignment system						
<b>Art. 99H</b>	Cod.	5.99.H1000				
Distanziale per supporto Spacer support						
<b>Art. 62K DPG 250</b>	Cod.	5.62.K801A5	5.62.K801A6	5.62.K801A7		
Piastra di interfaccia per cubo FMS completa di sistema d'allineamento Connecting plate with alignment system for FMS						
<b>Art. 99S</b>	<b>Dimensioni B mm</b> Dimension B mm		<b>A</b>	<b>C</b>	<b>Kg</b>	<b>Cod.</b>
Piastra base con cave e piani rettificati Base plate with slot and ground faces	650		400	50	102	7.99.S065S
	950		400	50	149	7.99.S095S
	1250		400	50	195	7.99.S125S

Cave o fori calibrati su richiesta - Slot or calibrated holes on request

Disponibili quote "B" a step di 50mm - Available dimension "B" in steps of 50mm

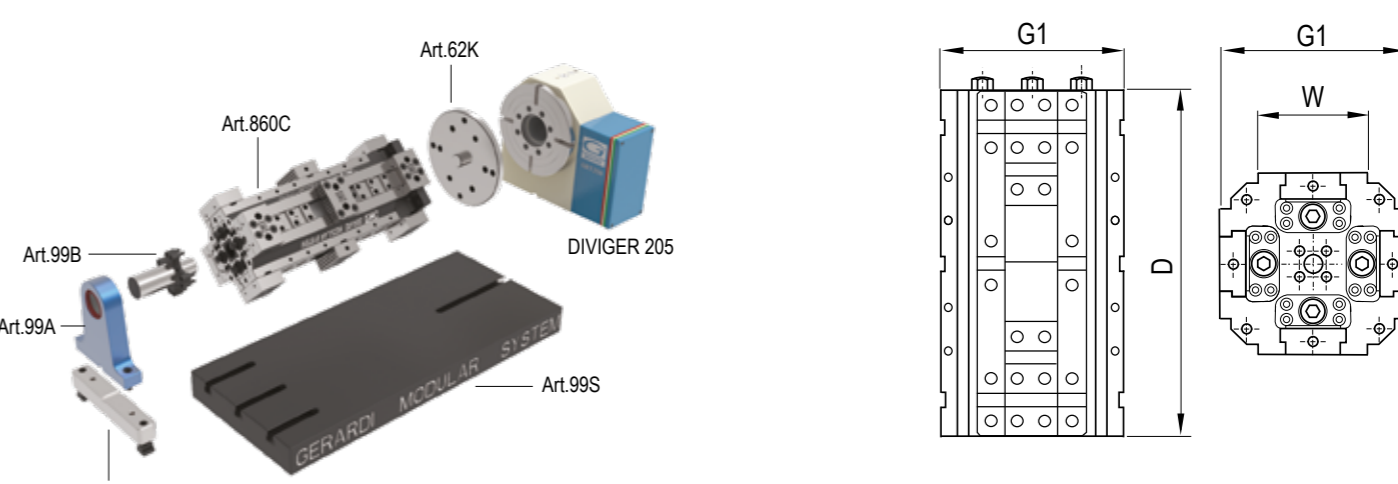

# DIVISORE MECCANICO DIVIGER 205

## MECHANICAL DIVIDING HEAD DIVIGER 205

**Divisore automatico**  
Automatic dividing head

**Dati tecnici**  
Technical Data

### DIVIGER 205



Diametro del divisore Dividing head diameter	220 mm
Diametro del foro passante Clearance hole diameter	85 mm
Altezza centrale Center height	200 mm
Dimensione della scanalatura a T T-Slot width	-
Sistema di bloccaggio Clamping system	Meccanico Mechanical
Minimo incremento Minimum increment	1°
Precisione Indexing accuracy	±10 Sec.
Coppia in lavoro Driving torque	3000 Nm
Kg	93
Cod.	7.66.73000

DIVISORE MECCANICO, SENZA CAVI O IDRAULICA,  
PERMACCHINE A CNC

MECHANICAL DIVIDING HEAD, WITHOUT ELECTRICAL CABLES  
OR HYDRAULIC, FOR CNC MILLING MACHINE

- Maggiore efficienza nella lavorazione su più lati
- Completamente autonomo dalla macchina
- Elevato momento torcente
- Divisione manuale o automatica tramite mandrino macchina
- 360 posizioni
- Serraggio simultaneo di due particolari grazie alla doppia flangia
- lavorazione su 5 facce senza contropunta
- Lavorazione a barra grazie al mandrino cavo
- Utilizzabile orizzontalmente o verticalmente
- Cambio tramite serraggio a cuneo

- Cost-effective on multiple-sides machining
- Machine independent
- High holding torque
- Dividing manually or automatically using the machine spindle
- 360 x 1° division
- Simultaneous clamping of 2 workpieces thanks to the dual flange
- 5 faces machining without counter-holder
- Bar machining due to hollow spindle
- To be used horizontally or vertically
- Quick change through wedge clamping



### DIVIGER 205

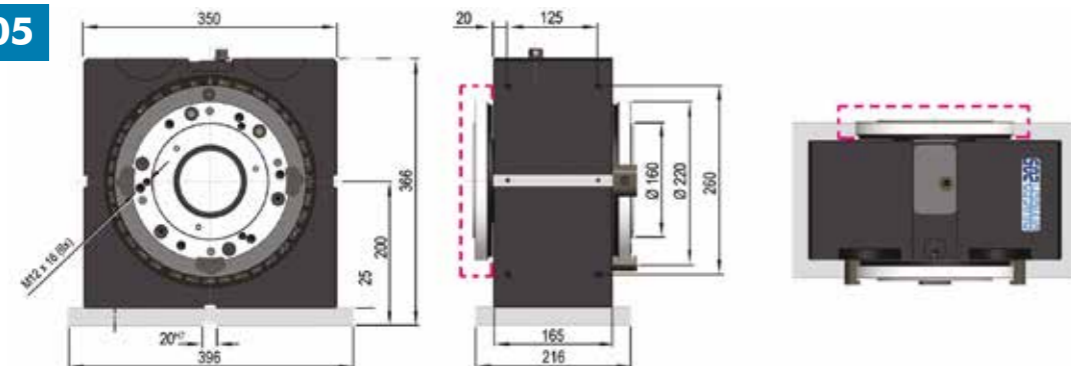

Tipo (grandezza) / Type (size)

kN	1		2				3				
	25 kN	300	25 kN		30 kN			30 kN			
D	200	300	300	400	500	600	400	500	600	700	800
G1	120				175					210	
W	74				94					124	
Cod.	5.D.I.V20500	5.D.I.V20510	5.D.I.V20520	5.D.I.V20530	5.D.I.V20540	5.D.I.V20550	5.D.I.V20560	5.D.I.V20570	5.D.I.V20580	5.D.I.V20590	5.D.I.V20511



Morse Art.860C  
Art.860C vises

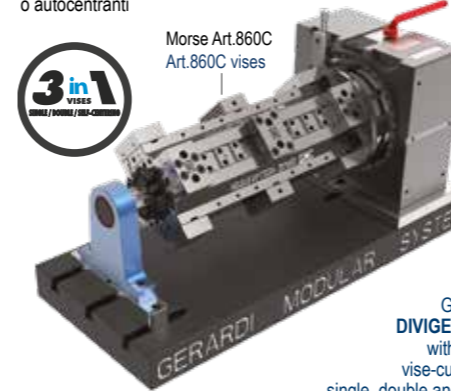

Gerardi  
DIVIGER 205  
with FMS  
vise-cube for  
single, double and self-  
centering clamping

Nel caso si disponga di un proprio divisore, il prezzo dell'attrezzatura potrebbe subire variazioni  
In case you already have a diviger, the price could be modified

### UPGRADE YOUR VISE APPLICATIONS THROUGH MODULAR ACCESSORIES !

#### Art. 99A

Supporto  
Support



Cod. 5.99.A1000

#### Art. 99B

Perno di centraggio completo  
di sistema d'allineamento

Horizontal centering pin with alignment system



Cod. 5.99.B1000 5.99.B2000 5.99.B3000

#### Art. 99H

Distanziale per supporto  
Spacer support



Cod. 5.99.H1000

#### Art. 62K

#### DIVIGER 205

Piastra di interfaccia per cubo FMS  
completa di sistema d'allineamento

Connecting plate with alignment system for FMS



Cod. 5.62.K801A5 5.62.K801A6 5.62.K801A7

#### Art. 99S

Piastra base con cave e piani rettificati  
Base plate with slot and ground faces

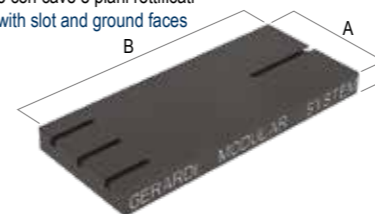



Dimensioni B mm Dimension B mm	A	C	Kg	Cod.
650	400	50	102	7.99.S065S
950	400	50	149	7.99.S095S
1250	400	50	195	7.99.S125S

Cave o fori calibrati su richiesta - Slot or calibrated holes on request

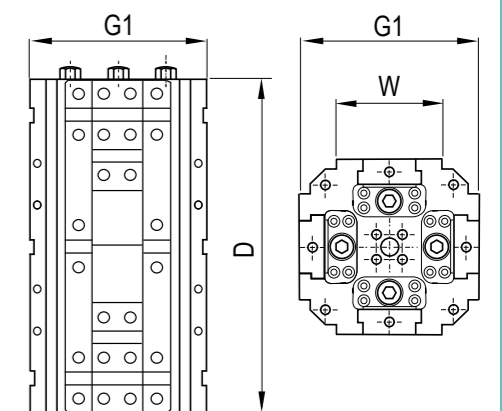
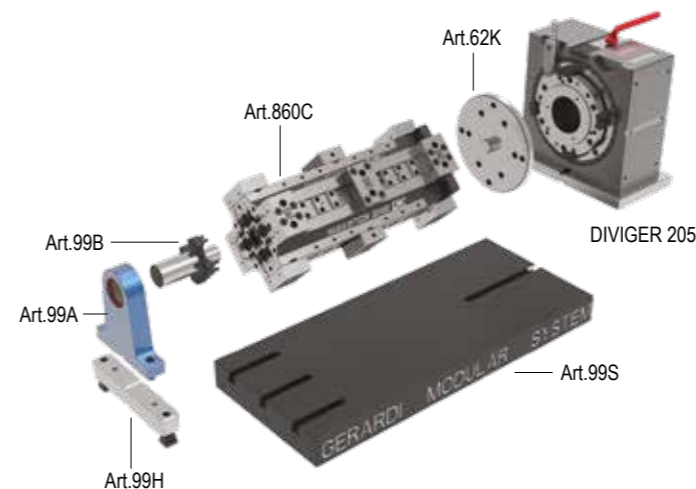
Disponibili quote "B" a step di 50mm - Available dimension "B" in steps of 50mm





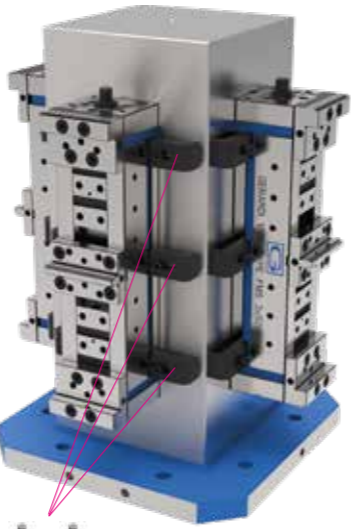

## PREDISPOSIZIONE e MONTAGGIO MORSE su CUBI LAVORATI TOMBSTONES SET-UP and VISES MOUNTING on MACHINED TOMBSTONES

Cubo lavorato Art.57C Machined cube Art.57C	Tipo di morsa Vise type	Predisposizione e montaggio* Set-up & Mounting*	Cubo con morse Cube with vises
<p>Cod. 8.53.C00081 Dim. A=250 / B=400 / H=660</p> 	<p>Art.864 Tipo 3x500</p> 	<p><b>Per morsa / each vise</b></p>  <p>Importo per lavorazioni necessarie per predisporre ogni faccia del cubo e montaggio più allineamento di ogni morsa. Amount needed for the set-up of each side and mounting + alignment of each vise on it.</p>	 <p>Art.296</p>
<p>n°morse Vises n° <b>x 4</b></p>			

\* Predisposizione facce cubo, montaggio ed allineamento morse incluso di viti, chiavette, staffe e quant'altro necessario.  
Faces set-up, vises mounting including screws, keyways, holding clamps and all the necessary equipment.

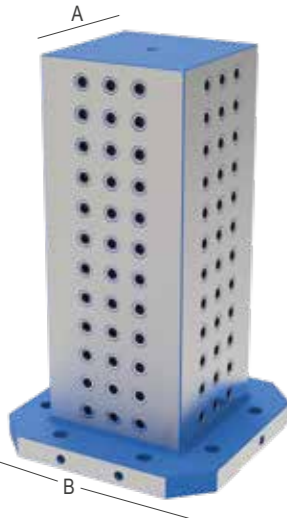
Certificato di collaudo  
Certificate test

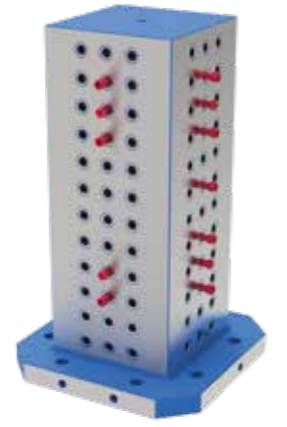
## PREDISPOSIZIONE e MONTAGGIO MORSE su CUBO a RETICOLO TOMBSTONES SET-UP and VISES MOUNTING on 2 GRID TOMBSTONES

Cubo a reticolo Art.53F Grid tombstone Art.53F	Tipo di morsa Vise type	Montaggio e allineamento* Mounting & alignment*	Cubo con morse Cube with vises
<p>Cod. 8.53.F00081 Dim. A=250 / B=400 / H=660</p> 	<p>Art.864 Tipo 3x500</p> 	<p><b>Per morsa / each vise</b></p>  <p>Importo per montaggio ed allineamento di ogni morsa. Amount need for each vise mounting and alignment.</p>	 <p>Art.83</p>
<p>n°morse Vises n° <b>x 4</b></p>			

\* Montaggio e allineamento morse incluso di viti, chiavette, staffe e quant'altro necessario.  
Vises mounting and alignment includes screws, keyways, holding clamps and all the necessary equipment.

Certificato di collaudo  
Certificate test

## DISPOSITIVO TERZA MANO PER MORSE FMS DOPPIE THIRD HAND ACCESSORY FOR DOUBLE FMS VISES

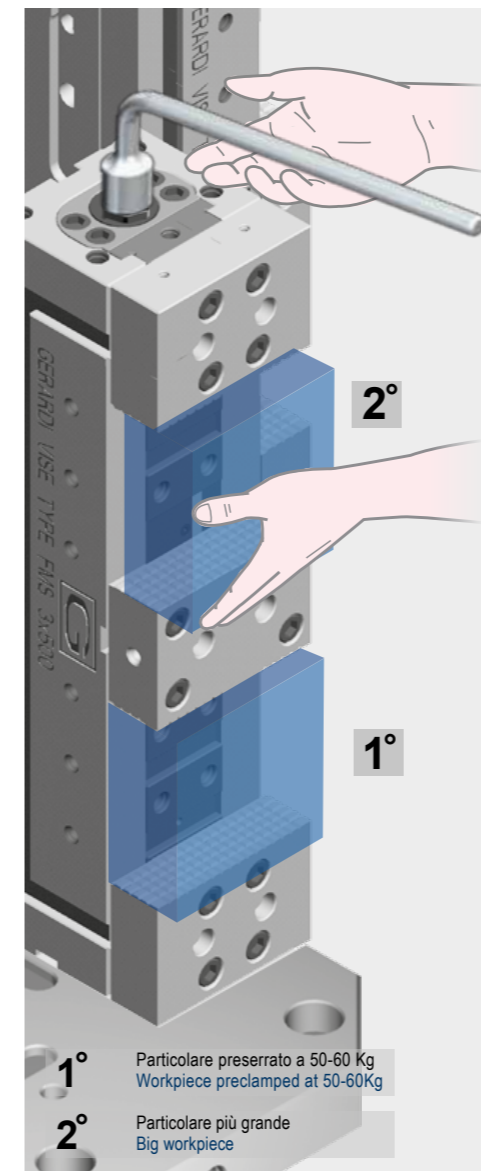

### DISPOSITIVO TERZA MANO PER MORSE FMS DOPPIE

Il meccanismo "Terza mano" nella morsa in versione a doppia stazione, consente il carico e serraggio lieve del primo pezzo (dalla parte opposta alla chiave nella stazione inferiore della morsa), mentre nel frattempo viene caricato il secondo pezzo di dimensione maggiore (da cui la denominazione "Terza mano"). Tale dispositivo risulta particolarmente utile quando la morsa viene usata in posizione verticale. Con il dispositivo "Terza mano", i due particolari da lavorare possono essere di dimensioni diverse con uno scarto massimo fra loro di 2 mm.

Il meccanismo "Terza mano" standard ha una spinta di max 50 Kg. Volendo ottenere una spinta maggiore, basta sostituire le molle in dotazione con altre di maggior potenza (attenzione però a mantenere la stessa quota di altezza del pacchetto molle) oppure aggiungendo un altro distanziale di max. 3mm  
**N.B:** sostituendo le molle o aggiungendo un distanziale extra bisogna tener presente che il maggior precarico comporterà lo stesso carico di spinta anche girando la vite Art.822 a vuoto.

Non volendo il meccanismo "Terza Mano", il tutto può essere semplicemente rimosso togliendo le molle con i relativi distanziali dalla loro sede naturale.

**Attenzione!!** Assicurarsi che Art.850N rimanga fissato nella morsa per proteggere l'eventuale entrata di trucioli.

### THIRD HAND DEVICE FOR DOUBLE STATION FMS VISES

The "Third Hand" device in the double station vise configuration, allows the first workpiece loaded to be gripped/clamped lightly with a little pressure (on the opposite side of the wrench and then in the lower vise station), while the second workpiece (bigger than first) is being loaded (from here the "third Hand" denomination). Such device is useful especially with the vise vertically positioned.

With the "Third Hand" device the two workpiece can be up to 2 mm different in gripping width.

The standard "Third Hand" device has a max pressure of 50 Kg.

In order to reach a higher clamping power it is enough to preload by changing the standard springs with more powerful ones or by adding a spacer (max 3 mm). Be careful that remains the same spring and spacer packing height dimensions.

**P.S:** By changing springs or adding extra spacer remember that the higher preload will give the same resistance (given by the more powerful preload) even just turning the main screw Art.822 freely.

If the "Third Hand" device is not required, it could be simply removed by taking away the springs and their spacers from their standard position.

**Attention!!** Make sure that the Art.850N remains fixed in the vise to provide protection from dirt getting inside the vise.

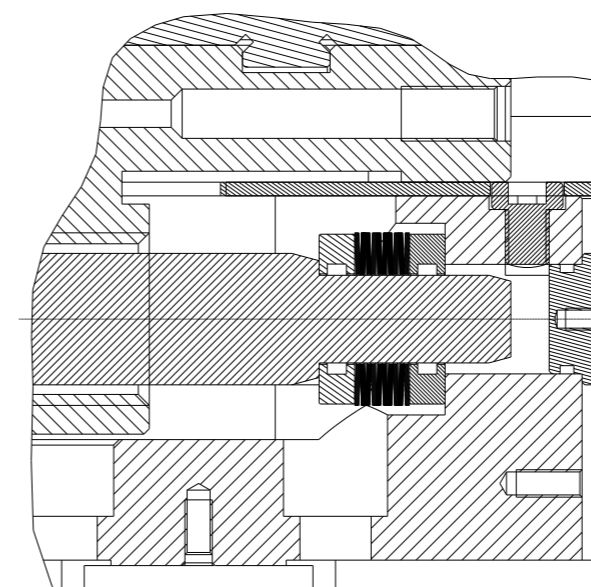

Art.850P



## Diagrammi di serraggio / Clamping diagrams

# FMS

### Diagrammi di serraggio meccanico con chiave dinamometrica

Mechanical clamping diagrams with torque wrench

Art. 357

#### Morse tipo Vises type

VITE: TPF 18 / 20 mm PASSO: 2 mm  
SCREW: TPF 18 / 20 mm PITCH: 2 mm

# 1

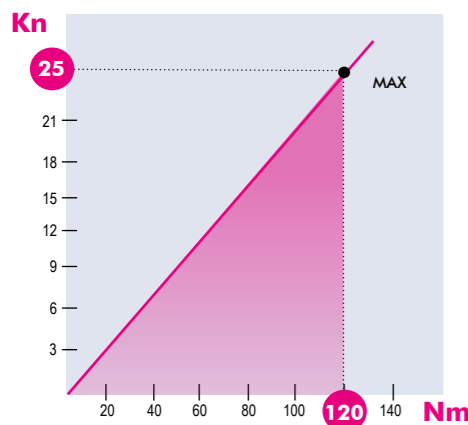

Art. 357

#### Morse tipo Vises type

VITE: TPF 18 / 24 mm PASSO: 2 mm  
SCREW: TPF 18 / 24 mm PITCH: 2 mm

# 2

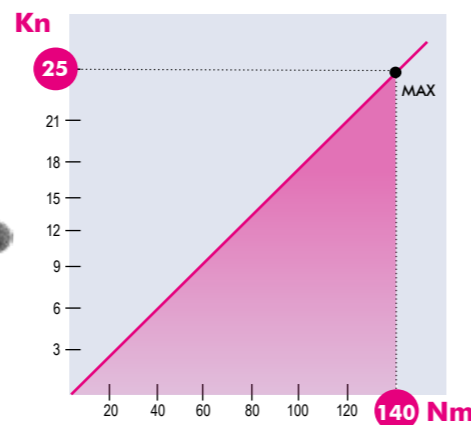

#### Morse tipo Vises type

VITE: TPF 24 / 30 mm PASSO: 2 mm  
SCREW: TPF 24 / 30 mm PITCH: 2 mm

# 3-4

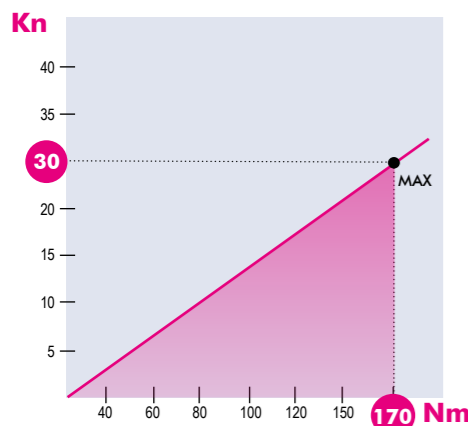

Art. 357

#### Morse tipo Vises type

VITE: TPF 30 / 36 mm PASSO: 3 mm  
SCREW: TPF 30 / 36 mm PITCH: 3 mm

# 5-6

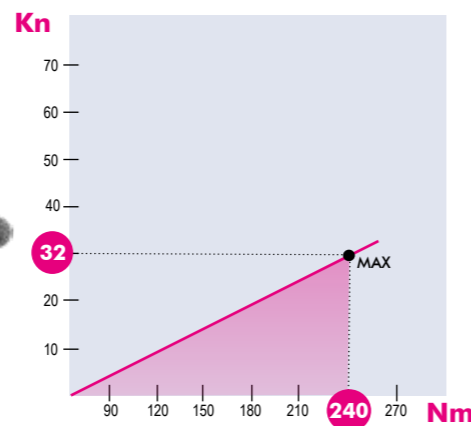

## Diagrammi serraggio / Clamping diagrams

# FMS

### Diagrammi di serraggio meccanico con moltiplicatore di potenza

Mechanical clamping diagrams with pressure multiplier

Art. 802

#### Morse tipo Vises type

VITE: TPF 18 / 20 mm PASSO: 2 mm  
SCREW: TPF 18 / 20 mm PITCH: 2 mm  
Rapporto trasmissione: 9:1  
Gear ratio: 9:1

# 1

Type 1 Cod. 5.80.21000 € 906

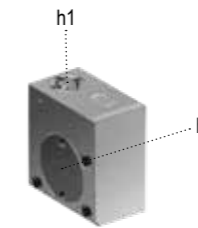
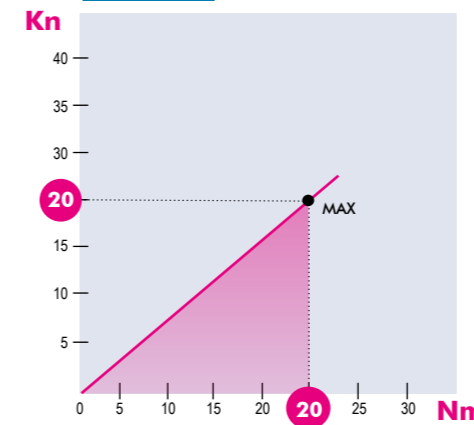

Art. 802

RATIO = h1 : h2

#### Morse tipo Vises type

VITE: TPF 24 / 30 mm PASSO: 2 mm  
SCREW: TPF 24 / 30 mm PITCH: 2 mm  
Rapporto trasmissione: 7:1  
Gear ratio: 7:1

# 3-4

Type 3 Cod. 5.80.23000 € 953

Type 4 Cod. 5.80.24000 € 1.171

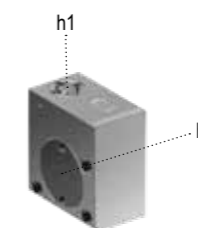
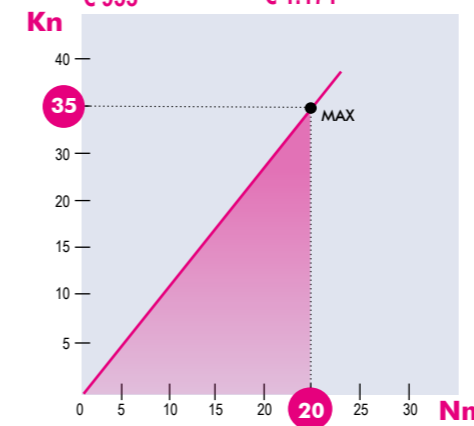

Art. 802

RATIO = h1 : h2

#### Morse tipo Vises type

VITE: TPF 18 / 24 mm PASSO: 2 mm  
SCREW: TPF 18 / 24 mm PITCH: 2 mm  
Rapporto trasmissione: 7:1  
Gear ratio: 7:1

# 2

Type 2 Cod. 5.80.22000 € 906

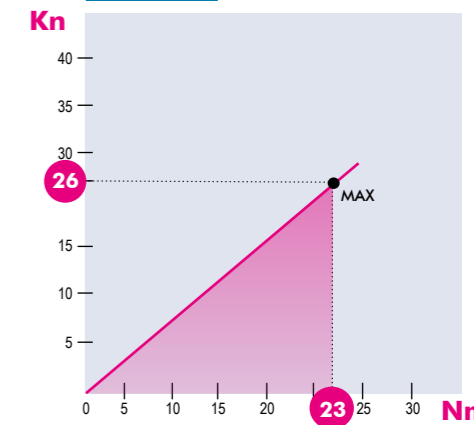

RATIO = h1 : h2

#### Morse tipo Vises type

VITE: TPF 30 / 36 mm PASSO: 3 mm  
SCREW: TPF 30 / 36 mm PITCH: 3 mm  
Rapporto trasmissione: 7:1  
Gear ratio: 7:1

# 5-6

Type 5 Cod. 5.80.25000 € 1.278

Type 6 Cod. 5.80.26000 € 1.270

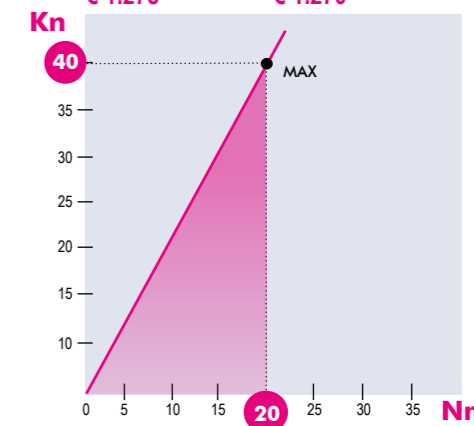

RATIO = h1 : h2

NB: Alcuni fattori, come la lubrificazione, lo staffaggio, gli attriti ed altro, possono modificare i valori indicati fino a ± 10%. Per un corretto utilizzo non superare i valori indicati nel grafico  
Some factor as lubrication, clamping on the machine table, frictions and more can modify above values within a ± 10% range. For optimum operation do not exceed chart values.

NB: Alcuni fattori, come la lubrificazione, lo staffaggio, gli attriti ed altro, possono modificare i valori indicati fino a ± 10%. Per un corretto utilizzo non superare i valori indicati nel grafico  
Some factor as lubrication, clamping on the machine table, frictions and more can modify above values within a ± 10% range. For optimum operation do not exceed chart values.

## Diagrammi serraggio / Clamping diagrams

# FMS

### Diagrammi di serraggio meccanico tramite motore idraulico

Mechanical clamping diagrams through hydraulic motor **Art. 890**

#### Morse tipo Vises type

VITE: TPF 18 / 20 mm PASSO: 2 mm  
SCREW: TPF 18 / 20 mm PITCH: 2 mm  
Motore idraulico tipo **OMM 32**  
Hydraulic motor type **OMM 32**

**1**

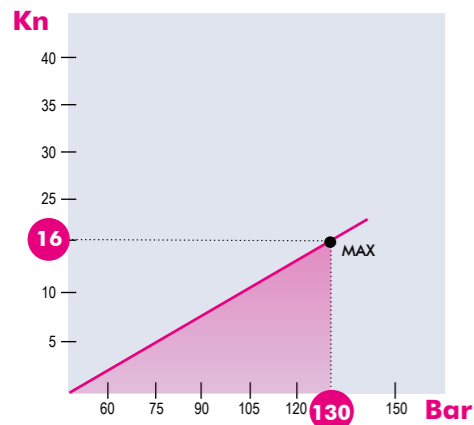

Art. 890

#### Morse tipo Vises type

VITE: TPF 18 / 24 mm PASSO: 2 mm  
SCREW: TPF 18 / 24 mm PITCH: 2 mm  
Motore idraulico tipo **OMP 80**  
Hydraulic motor type **OMP 80**

**2**

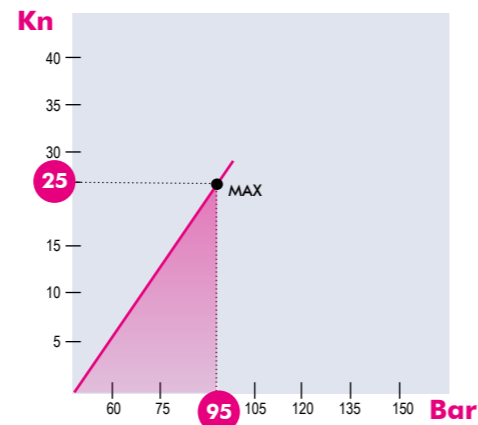

#### Morse tipo Vises type

VITE: TPF 24 / 30 mm PASSO: 2 mm  
SCREW: TPF 24 / 30 mm PITCH: 2 mm  
Motore idraulico tipo **OMR 200**  
Hydraulic motor type **OMR 200**

**3-4**

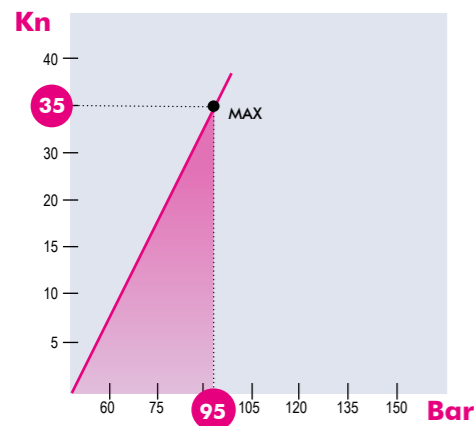

Art. 890

#### Morse tipo Vises type

VITE: TPF 30 / 36 mm PASSO: 3 mm  
SCREW: TPF 30 / 36 mm PITCH: 3 mm  
Motore idraulico tipo **OMR 200**  
Hydraulic motor type **OMR 200**

**5-6**

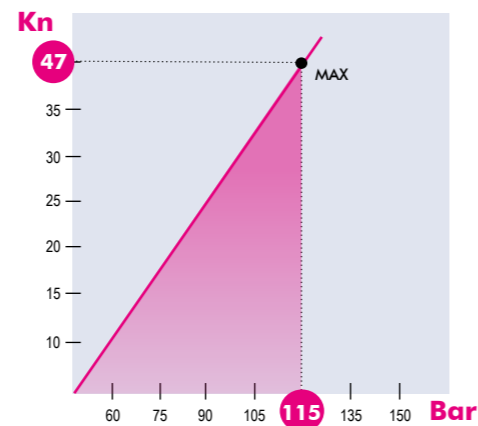

**ATTENZIONE! Azionamento idraulico ma serraggio meccanico (PIU' SICURO) - IMPORTANT!** Hydraulic control, but mechanical clamping (SAFER)

NB: Alcuni fattori, come la lubrificazione, lo staffaggio, gli attriti ed altro, possono modificare i valori indicati fino a  $\pm 10\%$ . Per un corretto utilizzo non superare i valori indicati nel grafico  
Some factor as lubrication, clamping on the machine table, frictions and more can modify above values within a  $\pm 10\%$  range. For optimum operation do not exceed chart values.

## ISTRUZIONI PER UN CORRETTO UTILIZZO

### ISTRUCTIONS FOR A PROPER USE



#### Libretto Istruzioni / Instruction Book

Scansiona il QR code e scarica le istruzioni complete

Scan the QR code to download the complete instructions

#### TOLLERANZE GEOMETRICHE

#### GEOMETRIC ACCURACIES

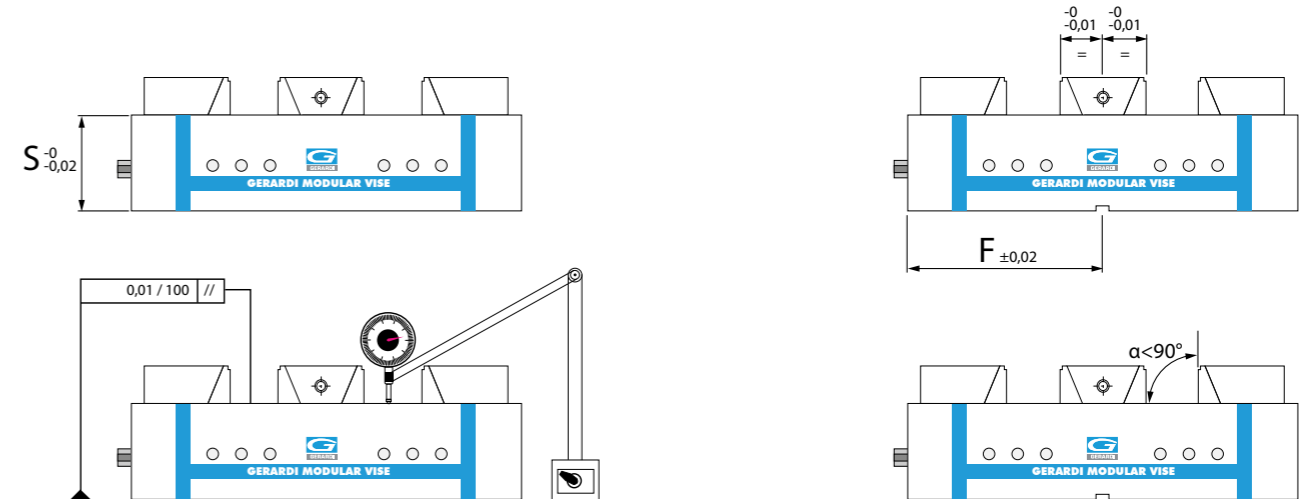

#### TOLLERANZE DINAMICHE

#### DINAMIC ACCURACIES

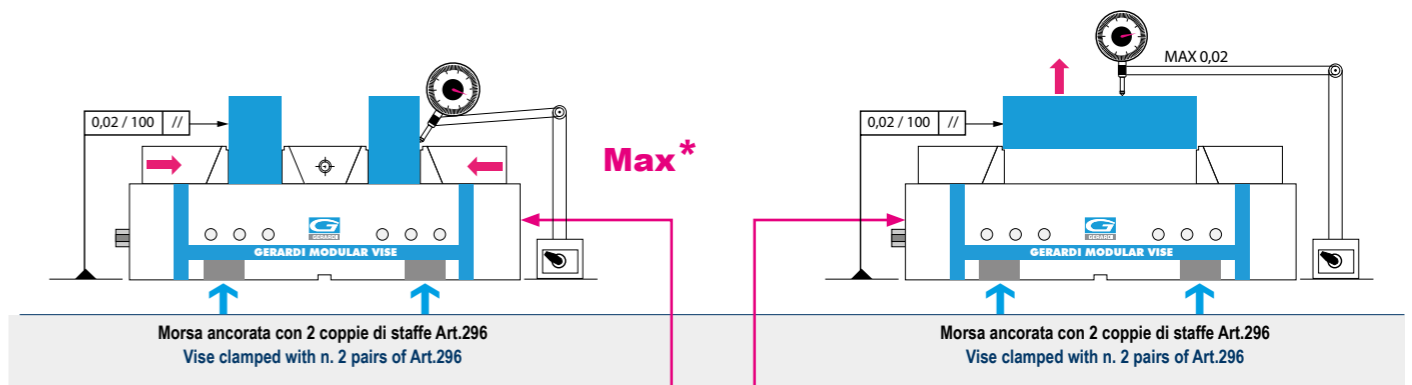

Art 865	* Coppia applicata - Torque Nm	Forza di serraggio - Clamping power
Morsa tipo 1 Vise type 1	120	2500 Kgf
Morsa tipo 2 Vise type 2	140	2500 Kgf
Morsa tipo 3 Vise type 3	180	3000 Kgf
Morsa tipo 4 Vise type 4	180	3000 Kgf
Morsa tipo 5 Vise type 5	240	3200 Kgf
Morsa tipo 6 Vise type 6	240	3200 Kgf

\* Max coppia applicabile per non superare i valori consigliati

1 kgf . m = 9.806

**ESTREMA VERSATILITY**  
**EXTREME VERSATILITY**

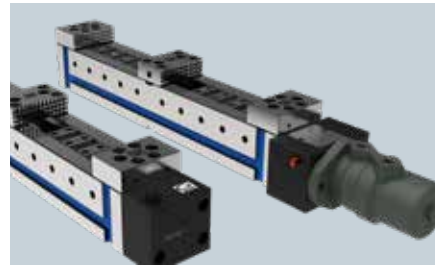

Sistema di serraggio meccanico, idraulico, pneumatico elettrico o con moltiplicatore di potenza, tramite comando manuale, a pedale o mediante pulsante elettrico (vedi pag. 12)

Mechanic, hydraulic or pneumatic or electrical clamping system or with pressure multiplier, through manual, pedal or push button control (see page 12)

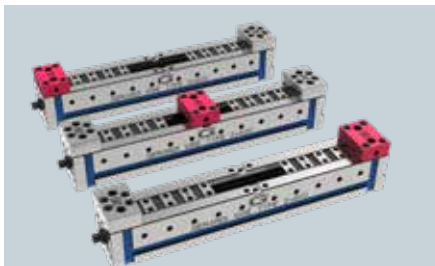

3 posizioni per la ganaschia fissa  
3 positions for the fixed jaw

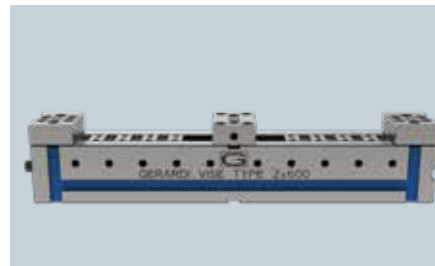

Costruzione solida e compatta e massima apertura rispetto alla sua lunghezza

Space saving design, solid construction and maximum blocking ratio to total length



Serraggio dall'esterno all'interno e viceversa  
Outside to inside clamping and viceversa

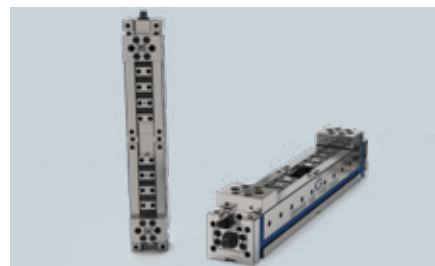

Precisioni geometriche con tolleranze entro 0,02mm

Geometrical accuracy with tolerances within 0,02 mm

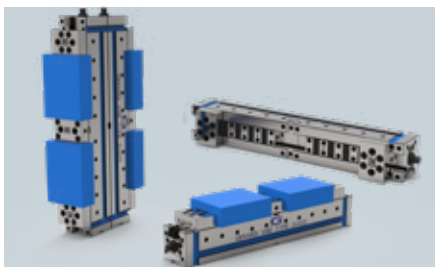

Posizionamento verticale-orizzontale laterale grazie alle chiavette longitudinali e trasversali sia sulla base che in testa  
Vertically, horizontally and sideway vise positioning by the

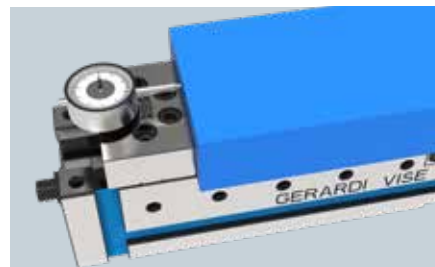

Accurata ripetibilità di posizionamento dei particolari da lavorare

Very accurate repeatability of workpieces position



Collegamento: fianco a fianco, dorso a dorso  
Side by side, back to back vise positioning

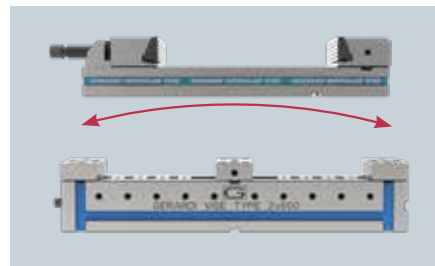

Flessioni ridotte di due volte rispetto alle morse modulari STANDARD

Bending reduced two times with respect to the STANDARD modular vises



Possibilità illimitata per ganasce speciali  
Unlimited range of special jaws

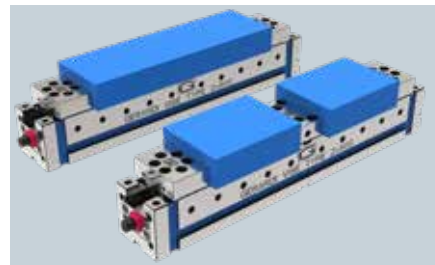

Trasformazione da autocentrante a doppia tramite la sostituzione delle ganasce sul corpo base universale e tramite la ghiera di regolazione.

Transform each single vise in a self-centering with possibility to block from outside to inside and vice versa and in a double vise through the substitution of the jaws on the universal vise body base and by the setting nut.

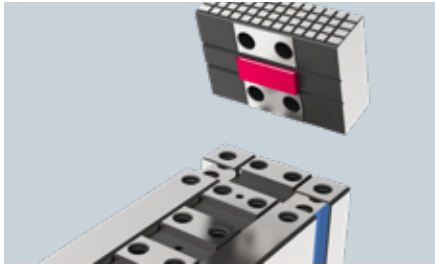

Sostituzione semplice e precisa delle ganasce  
Simple and precise exchange of jaws

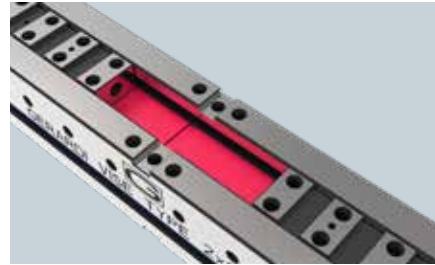

Protezione integrale dalla penetrazione di corpi estranei tramite piastre scorrevoli

Integral protection from chips and dirty through sliding protections

5